

SAMPLE PAPER

CHEMISTRY

CLASS 12

Set - 1
CHEMISTRY

Time Allowed: 3 Hours

Maximum Marks: 70

General Instructions:

Read the following instructions carefully.

- (a) There are 33 questions in this question paper with internal choice.
- (b) SECTION A consists of 16 multiple-choice questions carrying 1 mark each.
- (c) SECTION B consists of 5 short answer questions carrying 2 marks each.
- (d) SECTION C consists of 7 short answer questions carrying 3 marks each.
- (e) SECTION D consists of 2 case-based questions carrying 4 marks each.
- (f) SECTION E consists of 3 long answer questions carrying 5 marks each.
- (g) All questions are compulsory.
- (h) Use of log tables and calculators is not allowed.

SECTION A

The following questions are multiple-choice questions with one correct answer. Each question carries 1 mark. There is no internal choice in this section.

1. Given below are two figures of Daniell cell (X) and (Y). Study the figures and mark the incorrect statement from the following.

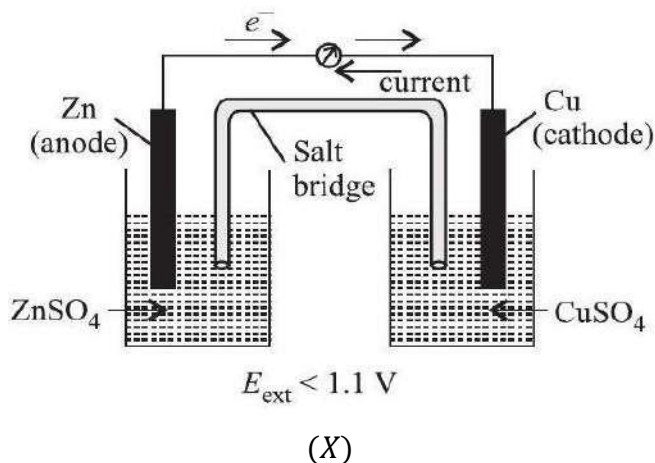

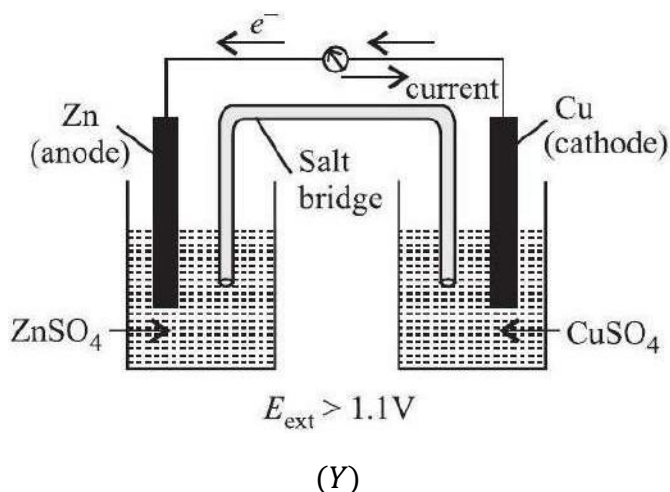

- (a) In fig (X), electrons flow from Zn rod to Cu rod hence current flows from Cu to Zn ($E_{\text{ext}} < 1.1\text{V}$).
- (b) In fig (Y), electrons flow from Cu to Zn and current flows from Zn to Cu ($E_{\text{ext}} > 1.1\text{V}$).
- (c) In fig (X), Zn dissolves at anode and Cu deposits at cathode.
- (d) In fig (Y), Zn is deposited at Cu and Cu is deposited at Zn.
2. Propanone on reaction with alkyl magnesium bromide followed by hydrolysis will produce
- primary alcohol
 - secondary alcohol
 - tertiary alcohol
 - carboxylic acid.
3. On boiling the egg, what structural changes are taking place in the egg white?
- The colour of the egg changes from colourless to white.
 - 2° and 3° structures are destroyed but 1° structure remains intact.
 - 1° , 2° and 3° structures of egg are destroyed.
 - A reversible change takes place which can be reversed by decreasing the temperature.
4. Which of the following compounds will undergo Cannizzaro reaction?
- CH_3CHO
 - CH_3COCH_3

(c) C_6H_5CHO

(d) $C_6H_5CH_2CHO$

5. Which of the following haloalkanes reacts with aqueous KOH most easily?
- (a) 1-Bromobutane
 - (b) 2-Bromobutane
 - (c) 2-Bromo-2-methylpropane
 - (d) 2-Chlorobutane
6. The second and third row elements of transition metals resemble each other much more than they resemble the first row because of
- (a) lanthanoid contraction which results in almost same radii of second and third row metals
 - (b) diagonal relationship between second and third row elements
 - (c) similar ionisation enthalpy of second and third row elements
 - (d) similar oxidation states of second and third row metals.
7. What will be the rate equation for the reaction $2X + Y \rightarrow Z$, if the order of the reaction is zero?
- (a) Rate = $k[X][Y]$
 - (b) Rate = k
 - (c) Rate = $k[X]^0[Y]$
 - (d) Rate = $k[X][Y]^0$
8. Which of the following has highest pK_b value?
- (a) $(CH_3)_3CNH_2$
 - (b) NH_3
 - (c) $(CH_3)_2NH$
 - (d) CH_3NH_2
9. IUPAC name of the given compound is

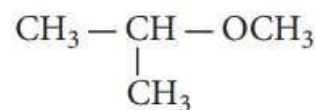

- (a) 1-methoxy-1-methylethane
- (b) 2-methoxy-2-methylethane

(c) 2-methoxypropane

(d) isopropylmethyl ether.

10. Two plots are shown below between concentration and time t . Which of the given orders are shown by the graphs respectively?

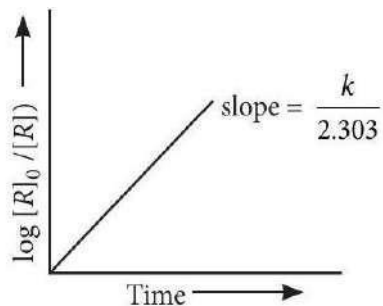
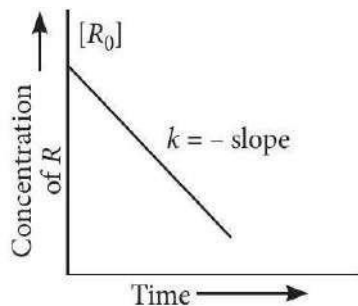

(a) Zero order and first order

(b) First order and zero order

(c) Zero order and zero order

(d) First order and first order

11. Which of the following reactions will not yield phenol?

(a)

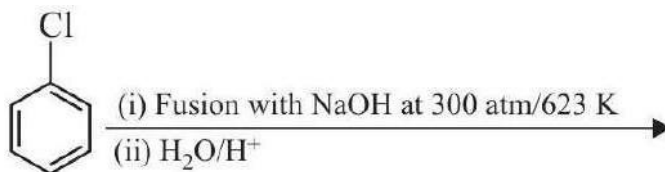

(b)

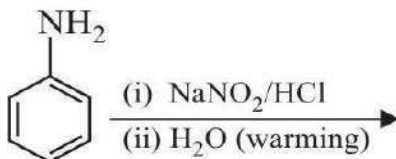

(c)

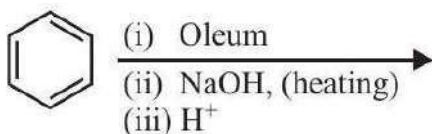

(d)

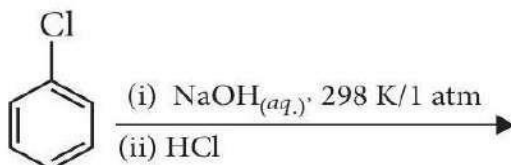

12. Which of the following transition metal ions is colourless?

- (a) V^{2+}
- (b) Cr^{3+}
- (c) Zn^{2+}
- (d) Ti^{3+}

13. Given below are two statements labelled as Assertion (A) and Reason (R).

Assertion (A): Picric acid is a strong acid inspite of absence of carboxylic group.

Reason (R): Three $-NO_2$ groups in picric acid activate the phenolate ion.

Select the most appropriate answer from the options given below:

- (a) Both A and R are true and R is the correct explanation of A.
- (b) Both A and R are true but R is not the correct explanation of A.
- (c) A is true but R is false.
- (d) A is false but R is true.

14. Given below are two statements labelled as Assertion (A) and Reason (R).

Assertion (A): Aldol condensation can be catalysed both by acids and bases.

Reason (R): β -Hydroxy aldehydes or ketones readily undergo acid catalysed dehydration.

Select the most appropriate answer from the options given below:

- (a) Both A and R are true and R is the correct explanation of A.
- (b) Both A and R are true but R is not the correct explanation of A.
- (c) A is true but R is false.
- (d) A is false but R is true.

15. Given below are two statements labelled as Assertion (A) and Reason (R).

Assertion (A): Purine bases present in DNA are adenine and guanine.

Reason (R): The base thymine is present in RNA while base uracil is present in DNA.

Select the most appropriate answer from the options given below:

- (a) Both A and R are true and R is the correct explanation of A.
- (b) Both A and R are true but R is not the correct explanation of A.
- (c) A is true but R is false.
- (d) A is false but R is true.

16. Given below are two statements labelled as Assertion (A) and Reason (R).

Assertion (A): The conductivity of electrolytic solution is greater than pure solvent.

Reason (R): Conductivity depends upon number of the ions present in solution.

Select the most appropriate answer from the options given below:

- (a) Both A and R are true and R is the correct explanation of A.
- (b) Both A and R are true but R is not the correct explanation of A.
- (c) A is true but R is false.
- (d) A is false but R is true.

SECTION B

This section contains 5 questions with internal choice in one question. The following questions are very short answer type and carry 2 marks each.

17. Rate constant ' k ' of a reaction varies with temperature T according to the equation:

$$\log k = \log A - \frac{E_a}{2.303R} \left(\frac{1}{T}\right)$$

where E_a is the activation energy. When a graph is plotted for $\log k$ vs $\frac{1}{T}$ a straight line with a slope of -4250 K is obtained. Calculate ' E_a ' for the reaction.

($R = 8.314 \text{ J K}^{-1} \text{ mol}^{-1}$).

18. (a) Which of the two, molarity or molality, is a better way to express the concentration of a solution and why?
- (b) An aqueous solution of 2% non-volatile solute exerts a pressure of 1.004 bar at the normal boiling point of the solvent. What is the molecular mass of the solute?
19. Arrange the following compounds in an increasing order of their property as indicated :
- (a) tert-butylbromide, methylbromide, sec-butylbromide, *n*-propylbromide (reactivity towards S_N2 hydrolysis)

(b) $\text{CH}_3\text{CH}_2\text{CH}(\text{Br})\text{COOH}$, $\text{CH}_3\text{CH}(\text{Br})\text{CH}_2\text{COOH}$, $(\text{CH}_3)_2\text{CHCOOH}$ (acidic strength)

20. Give reason :

(a) Aldehydes and ketones have lower boiling points than corresponding alcohols.

(b) Aldehydes are more reactive than ketones towards nucleophilic reagents.

OR

How will you convert ethanal into the following compounds :

(a) Butane-1, 3-diol

(b) But-2-enal?

21. What factors are responsible for the stability of α -helix structure of proteins?

SECTION C

This section contains 7 questions with internal choice in one question. The following questions are short answer type and carry 3 marks each.

22. Using valence bond theory, explain the following in relation to the complexes given below:

$[\text{Mn}(\text{CN})_6]^{3-}$, $[\text{Co}(\text{NH}_3)_6]^{3+}$, $[\text{Cr}(\text{H}_2\text{O})_6]^{3+}$

(a) Type of hybridisation

(b) Magnetic behaviour

(c) Spin only magnetic moment value

23. Attempt the following questions (any 2) :

(a) Calculate the standard electrode potential of Ni^{2+}/Ni electrode if emf of the cell

$\text{Ni}_{(s)}|\text{Ni}^{2+}(0.01\text{M}) \parallel \text{Cu}^{2+}(0.1\text{M})|\text{Cu}_{(s)}$ is 0.059 V. [Given : $E^\circ_{\text{Cu}^{2+}/\text{Cu}} = +0.34 \text{ V}$]

(b) Calculate the emf of the cell at 298 K.

$\text{Mg}_{(s)}|\text{Mg}^{2+}(0.001\text{M}) \parallel \text{Cu}^{2+}(0.0001\text{M})|\text{Cu}_{(s)}$

[Given: $E^\circ_{\text{Mg}^{2+}/\text{Mg}} = -2.37 \text{ V}$, $E^\circ_{\text{Cu}^{2+}/\text{Cu}} = 0.34 \text{ V}$]

(c) Calculate the emf of the following cell at 298 K :

$\text{Fe}_{(s)}|\text{Fe}^{2+}(0.001\text{M}) \parallel \text{H}^+(1\text{M})|\text{H}_{2(g)}(1\text{bar}) | \text{Pt}_{(s)}$

[Given: $E_{\text{Fe}^{2+}/\text{Fe}}^{\circ} = -0.44 \text{ V}$]

24. (a) Give chemical tests to distinguish between the following pairs of compounds:

(i) Pentan-2-ol and Pentan-3-ol

(ii) Ethanol and Phenol

(b) *o*-Nitrophenol is more acidic than *o*-methoxyphenol. Explain why.

25. (i) Acetone on reaction with HCN gives one compound, whereas acetaldehyde gives two compounds that are difficult to separate. Why?

(ii) Identify *A*, *B*, and *C* in the given sequence of reactions.

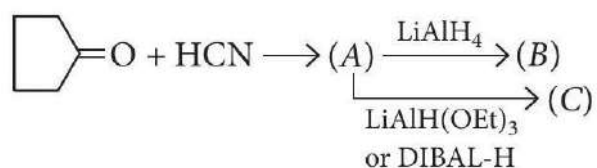

26. What happens when *D*-glucose is treated with the following reagents?

(a) Br₂ water

(b) HCN

(c) (CH₃CO)₂O

27. Write the structure of the major product in each of the following reactions:

(i)

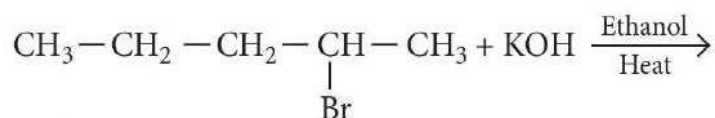

(ii)

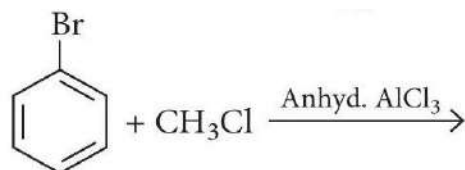

(iii)

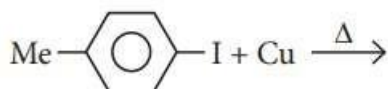

28. Following data are obtained for the reaction:

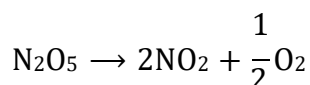

t/s	0	300	600
$[N_2O_5]/molL^{-1}$	1.6×10^{-2}	0.8×10^{-2}	0.4×10^{-2}

(i) Show that it follows first order kinetics.

(ii) Calculate the half-life.

(Given: $\log 2 = 0.3010, \log 4 = 0.6021$)

SECTION D

The following questions are case-based questions. Each question has an internal choice and carries 4(1 + 1 + 2) marks each. Read the passage carefully and answer the questions that follow.

29. Co(II) forms numerous complexes, which may be tetrahedral, octahedral or square planar. The monodentate ligands Cl^- , Br^- , I^- , OH^- and SCN^- commonly form tetrahedral complexes. The complex $Hg[Co(CNS)_4]$ is unusual, in this Co^{2+} is tetrahedrally coordinated by S-atoms giving a polymeric solid. This compound is often used to calibrate a magnetic balance when measuring magnetic moments. Square planar complexes are formed with several bidentate ligands such as dimethylglyoxime. Even though Co^{2+} is much more stable than Co^{3+} , many Co(II) complexes are readily oxidised to Co(III) complexes.

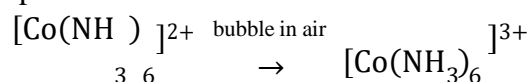

Answer the following questions:

- (a) Which of the following is more stable complex and why?

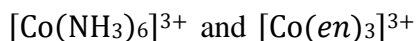

OR

Write IUPAC name of the linkage isomer of $[Co(NH_3)_5NO_2]Cl_2$.

- (b) Write the IUPAC name of the complex, $[Co(NH_3)_4(H_2O)Cl]Cl_2$

- (c) Write the state of hybridisation, the shape and the magnetic behaviour of the following complex:

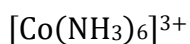

30. The study of the conductivity of electrolyte solutions is important for the development of electrochemical devices, for the characterisation of the dissociation equilibrium of weak electrolytes and for the fundamental understanding of charge transport by ions. The conductivity of electrolyte is

measured for electrolyte solution with concentrations in the range of 10^{-3} to 10^{-1} mol L⁻¹, as solution in this range of concentrations can be easily prepared. The molar conductivity (Λ_m) of strong electrolyte solutions can be nicely fit by Kohlrausch equation.

$$\Lambda_m = \Lambda_m^\circ - K\sqrt{C}$$

Where, Λ_m° is the molar conductivity at infinite dilution and C is the concentration of the solution. K is an empirical proportionality constant to be obtained from the experiment. The molar conductivity of weak electrolytes, on the other hand, is dependent on the degree of dissociation of the electrolyte. At the limit of very dilute solution, the Ostwald dilution law is expected to be followed,

$$\frac{1}{\Lambda_m} = \frac{1}{\Lambda_m^\circ} + \frac{\Lambda_m}{(\Lambda_m^\circ)^2} \frac{C_A}{K_d}$$

where, C_A is the analytical concentration of the electrolyte and K_d is dissociation constant. The molar conductivity at infinite dilution can be decomposed into the contributions of each ion.

$$\Lambda_m^\circ = v_+ \lambda_+^\circ + v_- \lambda_-^\circ$$

Where, λ_+ and λ_- are the ionic conductivities of positive and negative ions, respectively and v_+ and v_- are their stoichiometric coefficients in the salt molecular formula.

Answer the following questions:

(a) Give reason why conductivity of CH₃COOH decreases on dilution.

(b) The value of Λ_m° of Al₂(SO₄)₃ is 858 S cm² mol⁻¹, while λ_m° SO₄²⁻ is 160 S cm² mol⁻¹ calculate the limiting ionic conductivity of Al³⁺.

(c) Calculate Λ_m° for acetic acid.

Given that:

$$\Lambda_m^\circ(\text{HCl}) = 426 \text{ S cm}^2 \text{ mol}^{-1}$$

$$\Lambda_m^\circ(\text{NaCl}) = 126 \text{ S cm}^2 \text{ mol}^{-1}$$

$$\Lambda_m^\circ(\text{CH}_3\text{COONa}) = 91 \text{ S cm}^2 \text{ mol}^{-1}$$

OR

Calculate the degree of dissociation of acetic acid at 298 K, given that:

$$\Lambda_m^\circ(\text{CH}_3\text{COOH}) = 11.7 \text{ S cm}^2 \text{ mol}^{-1}$$

$$\Lambda_m^\circ(\text{CH}_3\text{COO}^-) = 49.9 \text{ S cm}^2 \text{ mol}^{-1}$$

$$\Lambda_m^\circ(\text{H}^+) = 349.1 \text{ S cm}^2 \text{ mol}^{-1}$$

SECTION E

The following questions are long answer type and carry 5 marks each. All questions have an internal choice.

31. Attempt any five of the following:

- How does ionisation enthalpy change along a transition series?
- Among the ionic species, Sc^{3+} , Ce^{4+} and Eu^{2+} , which one is a good oxidising agent?
- Transition metals have very high melting and boiling points. Why?
- The magnetic moment of a transition metal ion is found to be 3.87BM . How many numbers of unpaired electrons are present in it?
- Trivalent lanthanoid ions are coloured. Why?
- The observed E° value for Mn, Ni and Zn are more negative than expected. Explain.
- Ionisation enthalpies of actinoids are lower than that of corresponding lanthanoids. Why?

32. (i) Determine the osmotic pressure of a solution prepared by dissolving 2.5×10^{-2} g of K_2SO_4 in 2 L of water at 25°C , assuming that it is completely dissociated.

($R = 0.0821 \text{ L atm K}^{-1} \text{ mol}^{-1}$, molar mass of $\text{K}_2\text{SO}_4 = 174 \text{ g mol}^{-1}$)

(ii) A 4% solution (w/w) of sucrose ($M = 342 \text{ g mol}^{-1}$) in water has a freezing point of 271.15 K . Calculate the freezing point of 5% glucose ($M = 180 \text{ g mol}^{-1}$) in water. (Given: Freezing point of pure water = 273.15 K)

(iii) What happens when acetone is added to pure ethanol?

OR

(i) The vapour pressure of pure liquids A and B are 450 and 700 mmHg respectively, at 350 K. Find out the composition of the liquid mixture if total vapour pressure is 600 mmHg. Also find the composition of the vapour phase.

(ii) Give reasons for the following:

- Aquatic species are more comfortable in cold water than in warm water.
- At higher altitudes people suffer from anoxia resulting in inability to think.

33. (a) Write distinguish tests for the following pairs of compounds:

- Aniline and ethylamine
- Ethylamine and dimethylamine

(b) Account for the following:

(i) Aniline does not undergo Friedel-Crafts reaction.

(ii) It is difficult to prepare pure amines by ammonolysis of alkyl halides.

OR

(a) Arrange the following in increasing order of basic strength: Aniline, *p*-nitroaniline and *p*-toluidine.

(b) Account for the following:

(i) Like ammonia, amines are good nucleophiles.

(ii) In contrast to arenes, aliphatic hydrocarbons do not undergo nitration easily.

(c) Accomplish the following conversions:

(i) Aniline to *p*-bromoaniline

(ii) Benzamide to toluene

SAMPLE PAPER
SOLUTION
CHEMISTRY
CLASS 12

Set - 1
SOLUTIONS

1. (d) : In fig. (Y), zinc is deposited at the zinc electrode and copper dissolves at copper electrode.
2. (c) : HCHO gives primary alcohol, RCHO gives secondary alcohol while R_2CO gives tertiary alcohol on treatment with RMgX followed by hydrolysis.
3. (b): During denaturation of proteins, 2° and 3° structures are destroyed but primary (1°) structure remains intact.
4. (c) : Aldehydes with no α -H atom undergo Cannizzaro reaction on heating with conc. alkali solution. Hence, only C_6H_5CHO will undergo Cannizzaro reaction.
5. (c) : The tertiary carbocation formed in the reaction is more stable. So, 2-bromo-2-methylpropane undergoes hydrolysis easily with *aq.* KOH.
6. (a) : Due to lanthanoid contraction, the atomic radii of second and third row transition elements is almost same. Hence, they resemble each other much more as compared to first row elements.
7. (b) : Rate = $k[X]^0[Y]^0$ or rate = k
8. (b) : Higher the basicity, lower is the pK_b value. Since NH_3 is the weakest base, hence it has highest pK_b value.

9. (c) :

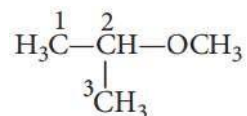

2-Methoxypropane

10. (a): Linear plots are obtained in the graph of concentration of R vs time for zero order reaction (with negative slope) and $\log([R]_0/[R])$ vs time for first order reaction (with positive slope).
11. (d) : Chlorobenzene does not undergo hydrolysis on treatment with aqueous NaOH at 298 K.
12. (c) : Zn^{2+} : $[Ar]3d^{10}$ has no unpaired electrons to be excited. Hence, it is colourless.
13. (c) : Three $-NO_2$ groups in picric acid deactivate the phenolate ion. Due to electron withdrawing nature of $-NO_2$ group, picric acid becomes stronger acid than phenol.
14. (b) : Both carbanions (formed in presence of base) and enol form (formed in presence of an acid) act as nucleophiles and hence add on the carbonyl group of aldehydes and ketones to give aldols.
15. (c) : Thymine is present in DNA while uracil is present in RNA.

16. (a): When electrolytes are dissolved in solvent they furnish their own ions in the solution hence, its conductivity increases.

17. Given : Slope, $m = -4250 \text{ K}$, $R = 8.314 \text{ J K}^{-1} \text{ mol}^{-1}$, $E_a = ?$

Using formula,

$$\log k = \log A - \frac{E_a}{2.303R} \left(\frac{1}{T}\right)$$

Comparing with $y = mx + c$ [straight line equation]

$$-\frac{E_a}{2.303R} = \frac{-4250}{1}$$

$$E_a = 2.303 \times 8.314 \text{ J K}^{-1} \text{ mol}^{-1} \times 4250 \text{ K}$$

$$= 81,375.35 \text{ J mol}^{-1} = 81.37 \text{ kJ mol}^{-1}$$

18. (a) Molarity of a solution is the number of moles of the solute dissolved per litre of the solution. The volume changes with temperature, i.e., molarity changes with change in temperature. However, molality is independent of temperature as it is the number of moles of the solute dissolved per kg of the solvent and mass does not vary with temperature. Thus, it is better to express concentration in terms of molality.

(b) Vapour pressure of pure water at its boiling point (p°) = 1 atm = 1.013bar

Vapour pressure of solution (p_s) = 1.004bar

Let mass of solution be 100 g, then,

Mass of solute (w_2) = 2 g

Mass of solvent (w_1) = 100 - 2 = 98 g

By Raoult's law for dilute solution,

$$\frac{p^\circ - p_s}{p^\circ} = \frac{n_2}{n_1} = \frac{w_2/M_2}{w_1/M_1} = \frac{w_2}{M_2} \times \frac{M_1}{w_1}$$

$$\frac{1.013 - 1.004}{1.013} = \frac{2}{M_2} \times \frac{18}{98}$$

$$M_2 = \frac{2 \times 18}{98 \times 8.88 \times 10^{-3}} = 41.36 \text{ g mol}^{-1}$$

19. (a) Reactivity order in S_N2 reaction will be methyl halides $> 1^\circ > 2^\circ > 3^\circ$.

More bulky substrates are least reactive toward S_N2 . Hence correct order is, methyl bromide $>$ n -propyl bromide $>$ sec-butyl bromide $>$ tert-butyl bromide.

(b) We know that $+I$ -effect decreases while $-I$ -effect increases the acid strength of carboxylic acids. The overall acid strength increases in the order :



20. (a) The boiling points of aldehydes and ketones are lower than that of corresponding alcohols and acids due to absence of intermolecular H-bonding in aldehydes and ketones.

(b) Ketones are less reactive than aldehydes towards nucleophilic addition reactions because:

The two electron releasing alkyl groups decrease the magnitude of positive charge on carbonyl carbon and make it less susceptible to nucleophilic attack.

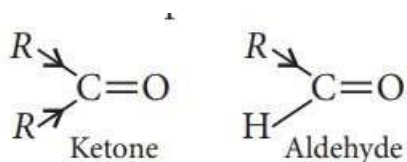

The two bulkier alkyl groups hinder the approach of the nucleophile to the carbonyl carbon. This is called steric factor.

OR

(a)

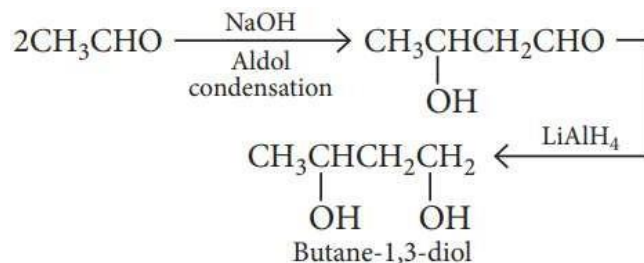

(b)

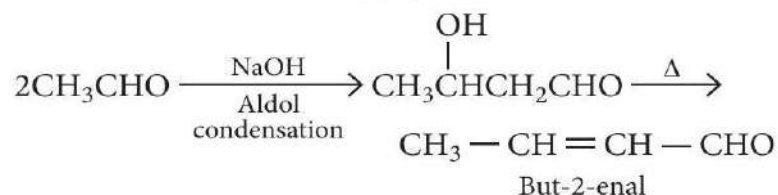

21. The stability of α -helix structure of proteins is due to intramolecular hydrogen bonding between —NH and —CO groups of the same peptide chain.

22. $[\text{Mn}(\text{CN})_6]^{3-}$:

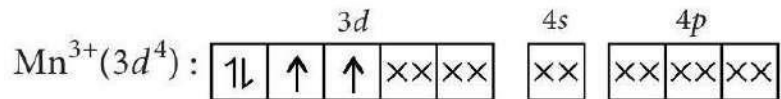

(a) Hybridisation $-d^2sp^3$

(b) Paramagnetic

(c) $\mu = \sqrt{2(2+2)} = 2.83$ B.M.

$[\text{Co}(\text{NH}_3)_6]^{3+}$:

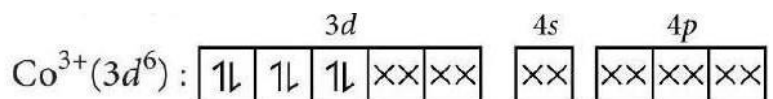

(a) Hybridisation $-d^2sp^3$

(b) Diamagnetic

(c) Magnetic moment (μ) = 0

$[\text{Cr}(\text{H}_2\text{O})_6]^{3+}$:

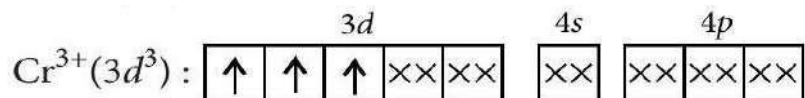

(a) Hybridisation $-d^2sp^3$

(b) Paramagnetic

(c) $\mu = \sqrt{3(3+2)} = 3.87$ B.M.

23. (a) : $\text{Ni}_{(s)} + \text{Cu}^{2+}_{(aq)} \rightarrow \text{Cu}_{(s)} + \text{Ni}^{2+}_{(aq)}$

$$E_{\text{cell}} = E_{\text{cell}}^{\circ} - \frac{0.059}{n} \log \frac{[\text{Ni}^{2+}]}{[\text{Cu}^{2+}]}$$

$$0.059 = E_{\text{cell}}^{\circ} - \frac{0.059}{2} \log \left(\frac{0.01}{0.1} \right) \text{ [Here, } n = 2 \text{]}$$

$$0.059 = E_{\text{cell}}^{\circ} - \frac{0.059}{2} \log \left(\frac{1}{10} \right)$$

$$0.059 = E_{\text{cell}}^{\circ} - \frac{0.059}{2} (-\log 10) \quad 0.059 = E_{\text{cell}}^{\circ} + \frac{0.059}{2} \Rightarrow E_{\text{cell}}^{\circ} = 0.059 - \frac{0.059}{2}$$

$$\therefore E_{\text{cell}}^{\circ} = \frac{0.059}{2} = 0.0295 \approx 0.03$$

$$\text{Now, } E_{\text{cell}}^{\circ} = E_{\text{cathode}}^{\circ} - E_{\text{anode}}^{\circ}$$

$$0.03 = 0.34 - E_{\text{anode}}^{\circ}$$

$$E_{\text{anode}}^{\circ} = 0.34 - 0.03 = 0.31 \text{ V}$$

$$\text{Hence, } E_{\text{Ni}^{2+}/\text{Ni}}^{\circ} = +0.31 \text{ V}$$

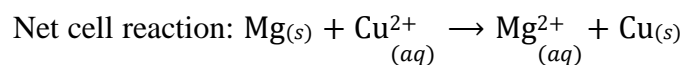
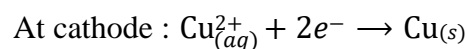
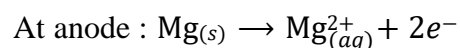
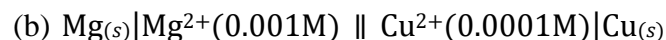

$$\therefore n = 2$$

Using Nernst equation,

$$E_{\text{cell}} = E_{\text{cell}}^{\circ} - \frac{2.303RT}{nF} \log \frac{[\text{Mg}^{2+}]}{[\text{Cu}^{2+}]}$$

For the given cell,

$$E_{\text{cell}}^{\circ} = E_{\text{cathode}}^{\circ} - E_{\text{anode}}^{\circ} = E_{\text{Cu}^{2+}/\text{Cu}}^{\circ} - E_{\text{Mg}^{2+}/\text{Mg}}^{\circ}$$

$$= 0.34 - (-2.37) = 2.71 \text{ V}$$

Given : $[\text{Mg}^{2+}] = 0.001\text{M}$, $[\text{Cu}^{2+}] = 0.0001\text{M}$

Putting these values in Nernst equation at 298 K,

$$E_{\text{cell}} = 2.71 - \frac{0.059}{2} \log \frac{0.001}{0.0001}$$

$$E_{\text{cell}} = 2.71 - 0.0295 \log 10 = 2.71 - 0.0295 = 2.68 \text{ V}$$

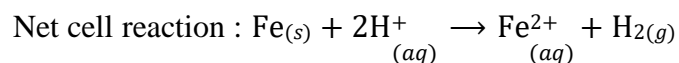
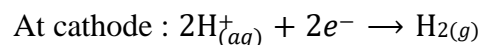
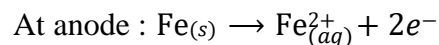

$$\therefore n = 2$$

Using Nernst equation at 298 K,

$$E_{\text{cell}} = E_{\text{cell}}^{\circ} - \frac{0.0591}{2} \log \frac{[\text{Fe}^{2+}] \times p_{\text{H}_2}}{[\text{H}^+]^2}$$

For the given cell,

$$\begin{aligned} E_{\text{cell}}^{\circ} &= E_{\text{cathode}}^{\circ} - E_{\text{anode}}^{\circ} = E_{\text{H}^+/\text{H}_2}^{\circ} - E_{\text{Fe}^{2+}/\text{Fe}}^{\circ} \\ &= 0 - (-0.44) = +0.44 \text{ V} \end{aligned}$$

Given : $[\text{Fe}^{2+}] = 0.001\text{M}$; $[\text{H}^+] = 1\text{M}$; $p_{\text{H}_2} = 1 \text{ bar}$

Putting values in Nernst equation,

$$\begin{aligned} E_{\text{cell}} &= 0.44 - 0.0295 \log \frac{0.001 \times 1}{1^2} \\ &= 0.44 - 0.0295 \log 10^{-3} = 0.44 - [(0.0295) \times (-3)] \\ &= 0.44 + 0.0885 = 0.53 \text{ V} \end{aligned}$$

24. (a) (i) Iodoform test : On adding I_2 and NaOH , 2-pentanol will give yellow precipitate of iodoform whereas 3-pentanol will not give yellow precipitate.

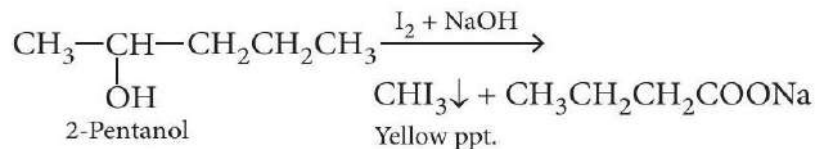

- (ii) FeCl_3 test: Phenol gives a violet colouration with FeCl_3 solution while ethanol does not.

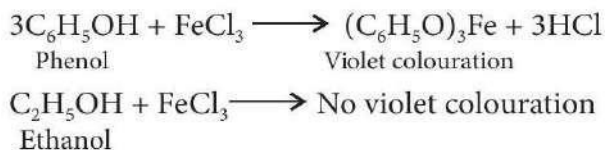

(b) As we know that the electron withdrawing groups enhance the acidic character of phenols because they help in the stabilisation of phenoxide ion by dispersing negative charge. Nitro group is an electron withdrawing group whereas methoxy group destabilise the phenoxide ion by intensifying the negative charge. Thus, *o*-nitrophenol is more acidic than *o*-methoxyphenol.

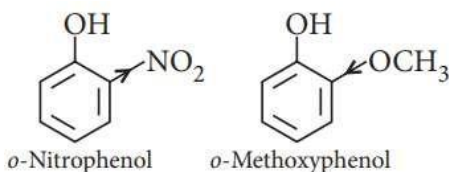

25. (i)

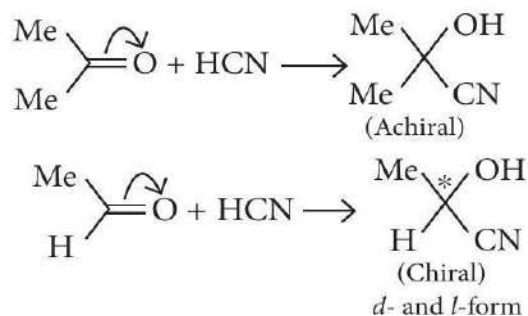

Acetaldehyde gives enantiomers (optical isomers) due to the chiral centre. They are difficult to separate since the chemical and physical properties of enantiomers are same.

(ii)

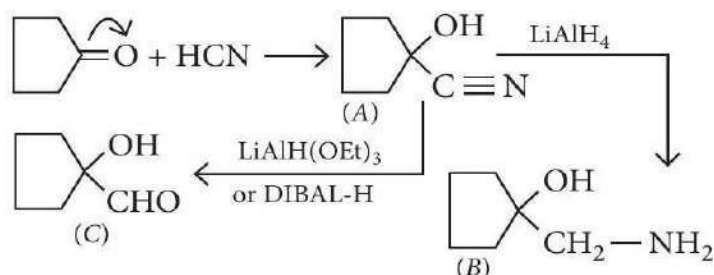

26. (a) *D*-Glucose gets oxidised to six carbon carboxylic acid (gluconic acid) on reaction with bromine water.

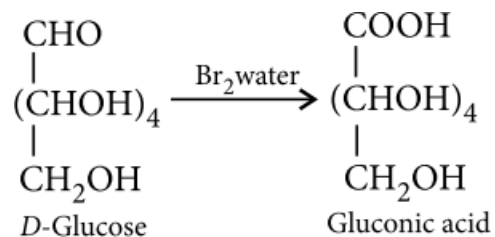

(b)

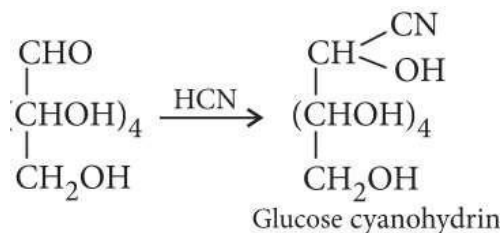

(c)

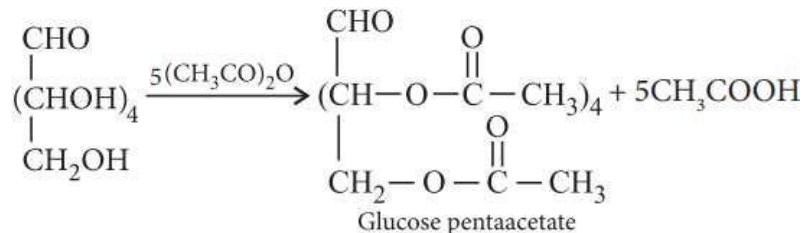

27. (i)

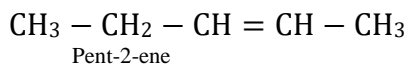

More substituted alkene is formed according to Saytzeff rule. Alkyl halide reacts with alc. KOH to produce alkene.

(ii)



(iii)

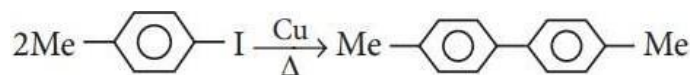

28. (i) The formula of rate constant for first order reaction is

$$k = \frac{2.303}{t} \log \frac{[R]_0}{[R]}$$

$$k_1 = \frac{2.303}{300 \text{ s}} \log \frac{(1.6 \times 10^{-2}) \text{ molL}^{-1}}{(0.8 \times 10^{-2}) \text{ molL}^{-1}} = 2.3 \times 10^{-3} \text{ s}^{-1}$$

$$\text{Similarly, } k_2 = \frac{2.303}{600 \text{ s}} \log \frac{(1.6 \times 10^{-2}) \text{ molL}^{-1}}{(0.4 \times 10^{-2}) \text{ molL}^{-1}}$$

$$= 2.3 \times 10^{-3} \text{ s}^{-1}$$

Unit and magnitude of rate constant shows the given reaction is of first order.

(ii) The formula for half-life for first order reaction is

$$t_{1/2} = \frac{0.693}{k} = \frac{0.693}{2.3 \times 10^{-3} \text{ s}^{-1}} = 301.30 \text{ s}$$

29. (a) $[\text{Co}(\text{en})_3]^{3+}$ is more stable complex than $[\text{Co}(\text{NH}_3)_6]^{3+}$ due to chelate effect as it forms rings.

OR

IUPAC name : Pentaamminenitrito-O-cobalt(III) chloride. $[\text{Co}(\text{NH}_3)_5(\text{ONO})]\text{Cl}_2$

(b) Tetraammineaquachloridocobalt(III) chloride

(c) $[\text{Co}(\text{NH}_3)_6]^{3+}$:

Co (27) : $1s^2 2s^2 2p^6 3s^2 3p^6 3d^7 4s^2$

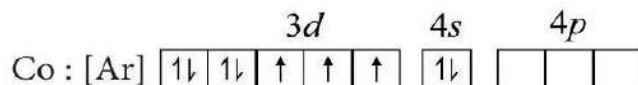

Configuration of Co^{3+} :

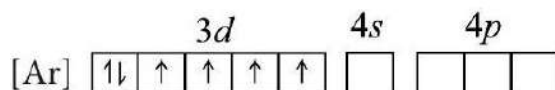

In the presence of strong field ligand NH_3 pairing of electrons takes place.

Hybridisation – d^2sp^3

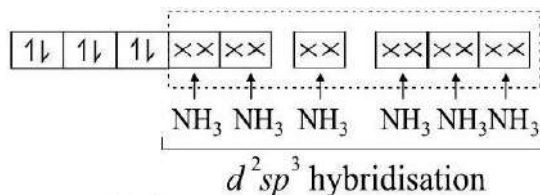

Shape - octahedral

Magnetic property - diamagnetic

30. (a) Conductivity of CH_3COOH (weak electrolyte) decreases with dilution because the number of current carrying particles i.e., ions present per cm^3 of the solution becomes less and less on dilution.

(b)

$$\Lambda_m^\circ \text{Al}_2(\text{SO}_4)_3 = 2\lambda_m^\circ \text{Al}^{3+} + 3\lambda_m^\circ \text{SO}_4^{2-}$$

$$858 = 2\lambda_m^\circ \text{Al}^{3+} + 3 \times 160$$

$$\Rightarrow \lambda_m^\circ \text{Al}^{3+} = \frac{858 - 480}{2} = 189 \text{ S cm}^2 \text{ mol}^{-1}$$

$$\begin{aligned}
 (c) \Lambda_m^{\circ}(\text{HCl}) &= \lambda_{\text{H}^+}^{\circ} + \lambda_{\text{Cl}^-}^{\circ} \\
 \Lambda_m^{\circ}(\text{NaCl}) &= \lambda_{\text{Na}^+}^{\circ} + \lambda_{\text{Cl}^-}^{\circ} \\
 \Lambda_m^{\circ}(\text{CH}_3\text{COONa}) &= \lambda_{\text{CH}_3\text{COO}^-}^{\circ} + \lambda_{\text{Na}^+}^{\circ} \\
 \Lambda_m^{\circ}(\text{CH}_3\text{COOH}) &= \lambda_{\text{CH}_3\text{COO}^-}^{\circ} + \lambda_{\text{H}^+}^{\circ} \\
 &= \lambda_{\text{H}^+}^{\circ} + \lambda_{\text{Cl}^-}^{\circ} + \lambda_{\text{CH}_3\text{COO}^-}^{\circ} - \lambda_{\text{Na}^+}^{\circ} + \lambda_{\text{Na}^+}^{\circ} - \lambda_{\text{Cl}^-}^{\circ} + \lambda_{\text{Na}^+}^{\circ} \\
 &= \Lambda_m^{\circ}(\text{HCl}) + \Lambda_m^{\circ}(\text{CH}_3\text{COONa}) - \Lambda_m^{\circ}(\text{NaCl}) \\
 &= 426 + 91 - 126 = 391 \text{ S cm}^2 \text{ mol}^{-1}
 \end{aligned}$$

OR

According to Kohlrausch's law,

$$\Lambda_m^{\circ}(\text{CH}_3\text{COOH}) = \lambda_{\text{CH}_3\text{COO}^-}^{\circ} + \lambda_{\text{H}^+}^{\circ}$$

$$\text{Degree of dissociation, } \alpha = \frac{\Lambda_m}{\Lambda_m^{\circ}}$$

$$= \frac{11.7 \text{ S cm}^2 \text{ mol}^{-1}}{(49.9 + 349.1) \text{ S cm}^2 \text{ mol}^{-1}} = \frac{11.7}{399} = 3 \times 10^{-2}$$

31. (a) From left to right in each series of transition elements, there is an increase in ionisation enthalpy due to increase in nuclear charge and decrease in atomic size.

(b) Ce^{4+} ; The stable oxidation state of lanthanoids is +3. Ce^{4+} tends to accept an electron to change to +3 state. Hence, it acts as a good oxidising agent.

(c) The high melting and boiling points of transition metals are attributed to the involvement of greater number of electrons from $(n-1)d$ -orbital in addition to the ns electrons in the interatomic metallic bonding ($d-d$ overlap).

(d) Magnetic moment, $\mu_{\text{eff}} = 3.87$ B.M. corresponds to the number of unpaired electrons, $n = 3$ by applying the formula.

$$\mu_{\text{eff}} = \sqrt{n(n+2)} \text{ B.M.}$$

For $n = 3, m = 3.87$ B.M.

(e) Trivalent lanthanoids are coloured due to presence of f -electrons. The excitation of electron in f -level imparts colour to them. This colour is caused due to $f-f$ transition. Some compounds show colour due to charge transfer also.

(f) Due to extra stability of the half-filled d sub-shell in Mn^{2+} and the completely filled d^{10} configuration in Zn^{2+} they have lower ionisation enthalpy and hence more negative E° values whereas for Ni, E° is negative due to the highest negative $\Delta_{\text{hyd}} H$ value.

(g) The 5 f -electrons are more effectively shielded from the nuclear charge than the 4 f -electrons of lanthanoids. Because the outer electrons are less firmly held hence their ionisation enthalpy is low.

32. (i) Mass of K_2SO_4 , $W_2 = 2.5 \times 10^{-2}$ g

Molar mass of K_2SO_4 , $M_2 = 174$ g mol $^{-1}$

$V = 2$ L, $T = 25^\circ\text{C} = 298$ K

$R = 0.0821$ L atm K $^{-1}$ mol $^{-1}$

We know, osmotic pressure, $\pi = \frac{W_2 RT}{M_2 V}$

$$\begin{aligned}\pi &= \frac{2.5 \times 10^{-2} \times 0.0821 \times 298}{174 \times 2} \\ &= \frac{61.1645 \times 10^{-2}}{348} = 0.1758 \times 10^{-2} \text{ atm}\end{aligned}$$

(ii) Molality of sucrose solution

$$= \frac{w_2 \times 1000}{M_2 \times w_1} = \frac{4 \times 1000}{342 \times 96} = 0.121 \text{ m}$$

ΔT_f for sucrose solution = $273.15 - 271.15 = 2$ K

$$K_f = \frac{\Delta T_f}{m} = \frac{2}{0.121} = 16.52 \text{ K/m}$$

Molality of glucose solution = $\frac{5 \times 1000}{180 \times 95} = 0.292$ m

$\Delta T_f = K_f \times m = 16.52 \times 0.292 = 4.82$ K

Freezing point of glucose solution

= $273.15 - 4.82 = 268.33$ K

(iii) A mixture of ethanol and acetone shows positive deviation from Raoult's law. Pure ethanol possesses hydrogen bonding. Introduction of acetone between the molecules of ethanol results in breaking of some of these hydrogen bonds. Due to weakening of interactions, the solution shows positive deviation from Raoult's law.

OR

(i) Given : $p_A^\circ = 450 \text{ mmHg}$, $p_B^\circ = 700 \text{ mmHg}$,

$P_{\text{Total}} = 600 \text{ mmHg}$, $x_A = ?$

Applying Raoult's law, $p_A = x_A \times p_A^\circ$

$$p_B = x_B \times p_B^\circ = (1 - x_A)p_B^\circ$$

$$\begin{aligned} P_{\text{Total}} &= p_A + p_B = x_A \times p_A^\circ + (1 - x_A)p_B^\circ \\ &= p_B^\circ + (p_A^\circ - p_B^\circ)x_A \end{aligned}$$

Substituting the given values, we get $600 = 700 + (450 - 700)x_A$ or, $250x_A = 100$

$$\text{or } x_A = \frac{100}{250} = 0.40$$

Thus, composition of the liquid mixture will be

$$x_A = 0.40; x_B = 1 - 0.40 = 0.60$$

Calculation of composition in the vapour phase,

$$p_A = x_A \times p_A^\circ = 0.40 \times 450 \text{ mmHg} = 180 \text{ mmHg}$$

$$p_B = x_B \times p_B^\circ = 0.60 \times 700 \text{ mmHg} = 420 \text{ mmHg}$$

Mole fraction of A in the vapour phase

$$= \frac{p_A}{p_A + p_B} = \frac{180}{180 + 420} = 0.30$$

Mole fraction of B in the vapour phase = $1 - 0.30 = 0.70$

(ii) (a) Increase in temperature decreases the solubility of oxygen in water. As a result, amount of dissolved oxygen decreases. It becomes more difficult to breathe as oxygen is less. Hence, the aquatic species are not comfortable in warm water.

(b) At high altitudes, the partial pressure of oxygen is less than at the ground level. As a result, there is a low concentration of oxygen in the blood and tissues of the people living at high altitudes. Thus, they feel weak and are unable to think properly, i.e., they suffer from anoxia.

33. (a) (i) Aniline gives white or brown precipitate with bromine water.

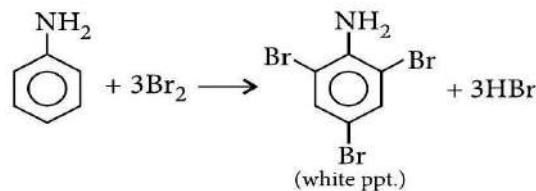

Ethylamine does not react with bromine water.

(ii) When ethylamine heated with an alcoholic solution of KOH and CHCl_3 , then it gives foul smelling of ethyl isocyanide.

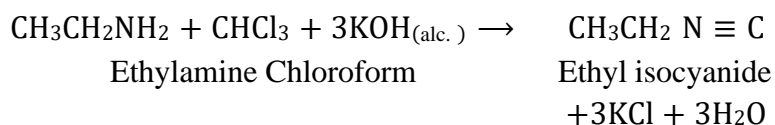

Dimethylamine does not give this test.

(b) (i) In Friedel-Crafts reaction, AlCl_3 is added as a catalyst which is a Lewis acid. It forms a salt with aniline due to which the nitrogen of aniline acquires positive charge. This positively charged nitrogen acts as a strong deactivating group, hence aniline does not undergo Friedel-Crafts reaction.

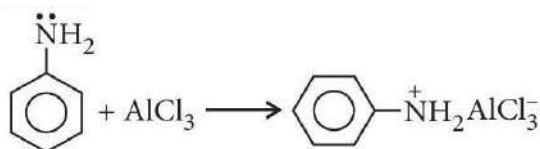

(ii) The ammonolysis of alkyl halides with ammonia is a nucleophilic substitution reaction in which ammonia acts as a nucleophile by donating the electron pair on nitrogen atom to form primary amine as the initial product. Now, the primary amine can act as a nucleophile and combine with alkyl halide (if available) to give secondary amine and the reaction continues in the same way to form tertiary amine and finally quaternary ammonium salt. Thus, a mixture of products is formed and it is not possible to separate individual amines from the mixture.

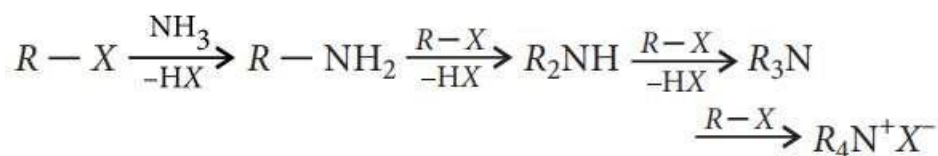

(a) Electron withdrawing group ($-\text{NO}_2$) on benzene ring decreases the basicity and electron donating group ($-\text{CH}_3$) on benzene ring increases the basicity of the compound.

Increasing order of basic strength :

p-nitroaniline < aniline < *p*-toluidine

(b) (i) Amines (like ammonia) are good nucleophiles. It is because alkyl group in an amine shows electron releasing effect. This increases the electron density on 'N' of amino group. This makes the amines very good nucleophiles.

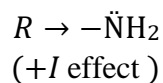

(ii) Arenes (unlike aliphatic hydrocarbons) undergo resonance. Thus negative charge gets delocalized on the benzene ring. This negative charge attracts the electrophiles that attack the benzene ring. This is not possible in aliphatic hydrocarbons.

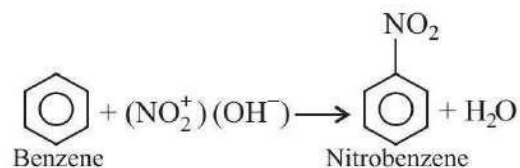

(c) (i)

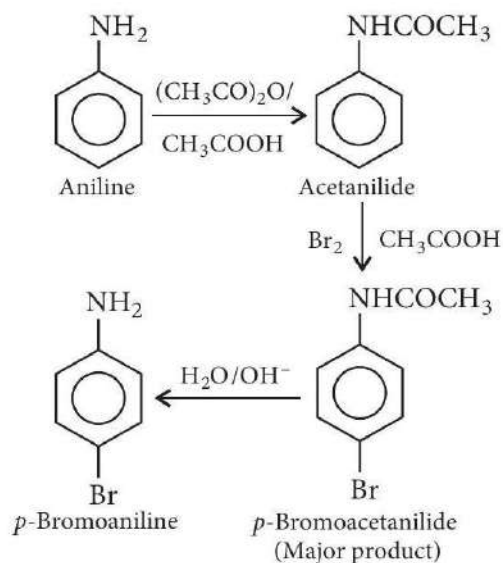

(ii)

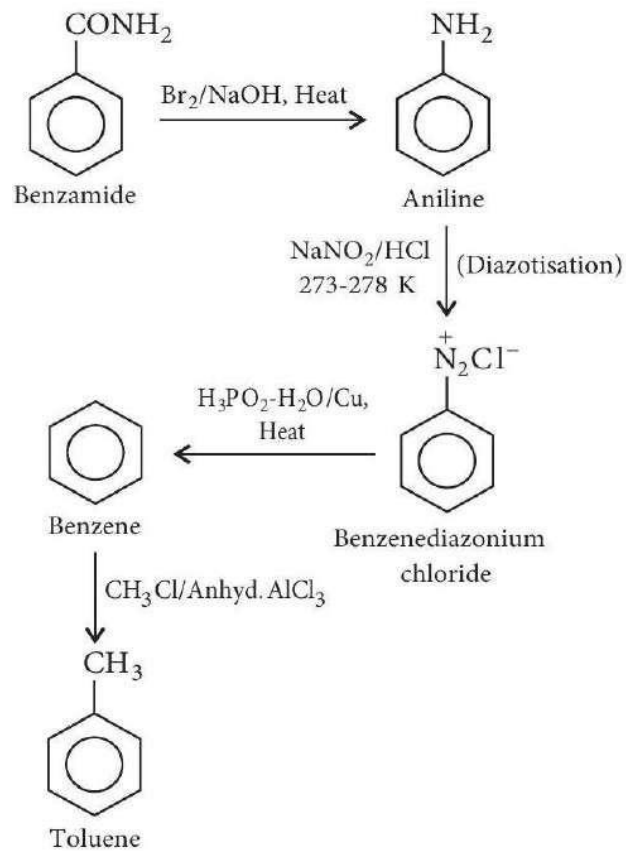

SAMPLE PAPER

CHEMISTRY

CLASS 12

SET-02
CHEMISTRY

Time Allowed: 3 Hours

Maximum Marks: 70

General Instructions:

Read the following instructions carefully.

- (a) There are 33 questions in this question paper with internal choice.
- (b) SECTION A consists of 16 multiple-choice questions carrying 1 mark each.
- (c) SECTION B consists of 5 short answer questions carrying 2 marks each.
- (d) SECTION C consists of 7 short answer questions carrying 3 marks each.
- (e) SECTION D consists of 2 case-based questions carrying 4 marks each.
- (f) SECTION E consists of 3 long answer questions carrying 5 marks each.
- (g) All questions are compulsory.
- (h) Use of log tables and calculators is not allowed.

SECTION A

The following questions are multiple-choice questions with one correct answer. Each question carries 1 mark. There is no internal choice in this section.

1. One mole of an organic compound *A* with the formula C_3H_8O reacts completely with two moles of HI to form *X* and *Y*. When *Y* is boiled with aqueous alkali, it forms *Z*. *Z* gives the iodoform test. The compound *A* is
 - (a) propan-2-ol
 - (b) propan-1-ol
 - (c) ethoxyethane
 - (d) methoxyethane.
2. Which of the following sequence is used to prepare α -hydroxypropanoic acid from ethanal?
 - (a) Treatment with HCN followed by acidic hydrolysis.
 - (b) Treatment with $NaHSO_3$ followed by reaction with Na_2CO_3 .
 - (c) Treatment with H_2SO_4 followed by hydrolysis.
 - (d) Treatment with $K_2Cr_2O_7$ in presence of sulphuric acid.
3. The correct order of increasing oxidizing power in the series is
 - (a) $VO_2^+ < Cr_2O_7^{4-} < MnO_4^-$

- (b) $\text{Cr}_2\text{O}_7^{2-} < \text{VO}^+ < \text{MnO}^-$
 (c) $\text{Cr}_2\text{O}_7^{2-} < \text{MnO}_4^{2-} < \text{VO}_4^{4-}$
 (d) $\text{MnO}_4^{2-} < \text{Cr}_2\text{O}_7^{2-} < \text{VO}_2^+$

4. While charging the lead storage battery,
 (a) PbSO_4 on cathode is reduced to Pb
 (b) PbSO_4 on anode is oxidized to PbO_2
 (c) PbSO_4 on anode is reduced to Pb
 (d) PbSO_4 on cathode is oxidized to Pb.
5. Glucose when reduced with HI and red phosphorus gives
 (a) *n*-hexane
 (b) *n*-heptane
 (c) *n*-pentane
 (d) *n*-octane.
6. The compound obtained when acetaldehyde reacts with dilute aqueous sodium hydroxide exhibits
 (a) geometrical isomerism
 (b) optical isomerism
 (c) neither optical nor geometrical isomerism
 (d) both optical and geometrical isomerism.
7. A first order reaction has a rate constant $k = 3.01 \times 10^{-3}/\text{s}$. How long it will take to decompose half of the reaction?
 (a) 2.303 s
 (b) 23.03 s
 (c) 230.2 s
 (d) 2303 s
8. The number of unpaired electrons in the square planar $[\text{Pt}(\text{CN})_4]^{2-}$ ion are
 (a) 2
 (b) 1
 (c) 0
 (d) 3
9. Which of the following compounds is not chiral?
 (a) 1-Chloropentane
 (b) 2-Chloropentane
 (c) 1-Chloro-2-methylpentane
 (d) 3-Chloro-2-methylpentane
10. Identify the incorrect statement among the following.
 (a) $4f$ - and $5f$ -orbitals are equally shielded.
 (b) *d*-Block elements show irregular and erratic chemical properties among themselves.
 (c) La and Lu have partially filled *d*-orbitals and no other partially filled orbitals.
 (d) The chemistry of various lanthanoids is very similar.

11. Arrange the following compounds in the increasing order of their acidic strengths :

- (i) *m*-Nitrophenol
 - (ii) *m*-Cresol
 - (iii) Phenol
 - (iv) *m*-Chlorophenol
- (a) $ii < iv < iii < i$
 - (b) $ii < iii < i < iv$
 - (c) $iii < ii < i < iv$
 - (d) $ii < iii < iv < i$

12. Which of the following amines will not give carbylamine reaction?

- (a) Ethyl amine
- (b) Phenyl amine
- (c) Methyl amine
- (d) Dimethyl amine

13. Given below are two statements labelled as Assertion (A) and Reason (R).

Assertion (A) : For a zero order reaction, plot of rate *vs* concentration will be a straight line parallel to concentration axis.

Reason (R) : For a zero order reaction, rate is independent of concentration.

Select the most appropriate answer from the options given below:

- (a) Both A and R are true and R is the correct explanation of A.
- (b) Both A and R are true but R is not the correct explanation of A.
- (c) A is true but R is false.
- (d) A is false but R is true.

14. Given below are two statements labelled as Assertion (A) and Reason (R).

Assertion (A) : Acetaldehyde can be prepared by addition of water to ethyne in the presence of H_2SO_4 and $HgSO_4$.

Reason (R) : Higher alkynes give higher aldehydes.

Select the most appropriate answer from the options given below:

- (a) Both A and R are true and R is the correct explanation of A.
- (b) Both A and R are true but R is not the correct explanation of A.
- (c) A is true but R is false.
- (d) A is false but R is true.

15. Given below are two statements labelled as Assertion (A) and Reason (R).

Assertion (A) : Glucose and fructose are reducing sugars.

Reason (R) : Glucose and fructose contain a free aldehydic and ketonic group adjacent to a $> \text{CHOH}$ group respectively.

Select the most appropriate answer from the options given below:

- (a) Both A and R are true and R is the correct explanation of A.
- (b) Both A and R are true but R is not the correct explanation of A.
- (c) A is true but R is false.
- (d) A is false but R is true.

16. Given below are two statements labelled as Assertion (A) and Reason (R).

Assertion (A) : The total number of isomers shown by $[\text{Co}(\text{en})_2\text{Cl}_2]^+$ complex ion is three.

Reason (R) : $[\text{Co}(\text{en})_2\text{Cl}_2]^+$ complex ion has an octahedral geometry.

Select the most appropriate answer from the options given below:

- (a) Both A and R are true and R is the correct explanation of A.
- (b) Both A and R are true but R is not the correct explanation of A.
- (c) A is true but R is false.
- (d) A is false but R is true.

SECTION B

This section contains **5** questions with internal choice in one question. The following questions are very short answer type and carry 2 marks each.

17. Convert the following:

- (a) Ethanoic acid into methanamine
- (b) Ethanamine into methanamine

18. Out of the various possible isomers of $\text{C}_7\text{H}_7\text{Cl}$ containing benzene ring, suggest the structure with the weakest C – Cl bond.

19. Distinguish between :

- (i) Essential and non-essential amino acids.

- (ii) α -Glucose and β -glucose.
20. When orange solution containing $\text{Cr}_2\text{O}_7^{2-}$ ions is treated with an alkali, a yellow solution is formed and when H^+ ions are added to yellow solution, an orange solution is obtained. Explain why does this happen?
21. In general, it is observed that the rate of a chemical reaction doubles with every 10°C rise in temperature. If this generalization holds for a reaction in the temperature range 295 K to 305 K. What would be the value of activation energy for this reaction? ($R = 8.314 \text{ J K}^{-1} \text{ mol}^{-1}$).

OR

A reaction is first order w.r.t A and second order w.r.t B .

- (i) Write differential rate equation.
- (ii) How is rate affected when concentration of B is tripled?

SECTION C

This section contains 7 questions with internal choice in one question. The following questions are short answer type and carry 3 marks each.

22. Give reason for the following :
- (i) Zinc salts are white while copper salts are coloured [At. nos. Zn = 30, Cu = 29].
- (ii) Europium (II) is more stable than cerium (II).
- (iii) Actinoid contraction is greater than lanthanoid contraction.
23. The decomposition of a compound is found to follow a first order rate law. If it takes 15 minutes for 20 percent of original material to react, calculate
- (i) the specific rate constant
- (ii) the time at which 10 percent of the original material remains unreacted,
- (iii) the time it takes for the next 20 percent of the reactant left after the first 15 minutes.
24. For the following compounds, give reason for the statements given below (any 2) :

- (a) Compound II follows S_N2 mechanism.
- (b) Compound IV undergoes inversion of configuration.
- (c) Compounds I and III follow S_N1 mechanism.

25. (a) A voltaic cell is set up at 25°C with the following half cells :

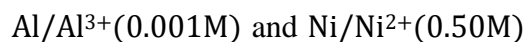

Write an equation for the reaction that occurs when the cell generates an electric current and determine the cell potential.

$E_{\text{Ni}^{2+}/\text{Ni}}^\circ = -0.25 \text{ V}$ and $E_{\text{Al}^{3+}/\text{Al}}^\circ = -1.66 \text{ V}$.

$(\log 8 \times 10^{-6} = -5.09)$

(b) Consider the figure and answer the following questions.

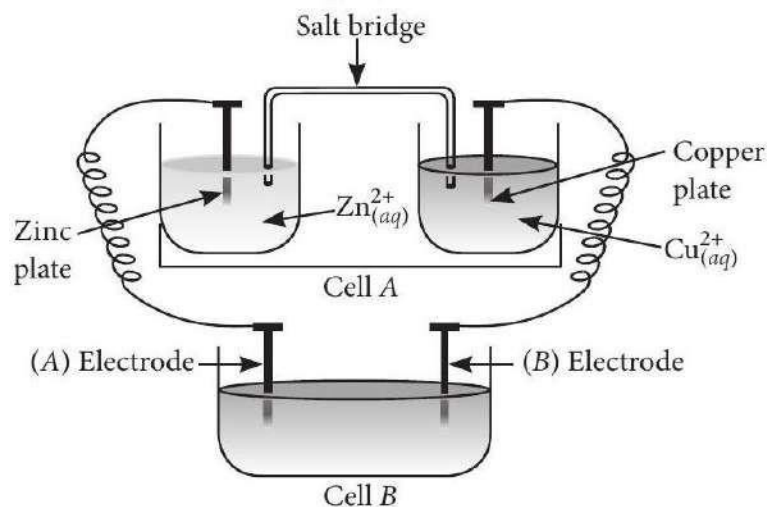

- (i) Cell 'A' has $E_{\text{cell}} = 2 \text{ V}$ and cell 'B' has $E_{\text{cell}} = 1.1 \text{ V}$, which of the two cells 'A' or 'B' will act as an electrolytic cell? Which electrode reactions will occur in this cell?
- (ii) If cell 'A' has $E_{\text{cell}} = 0.5 \text{ V}$ and cell 'B' has $E_{\text{cell}} = 1.1 \text{ V}$ then, what will be the reactions at anode and cathode?

26.26.

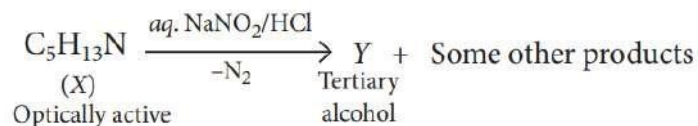

(i) Identify (X) and (Y).

- (ii) Is Y optically active?
- (iii) Give structures of intermediate(s) if any, in the formation of Y from X .
27. (a) Some ethylene glycol, $\text{HOCH}_2\text{CH}_2\text{OH}$, is added to your car's cooling system along with 5 kg of water. If the freezing point of water-glycol solution is -15.0°C , what is the boiling point of the solution?
($K_b = 0.52 \text{ K kg mol}^{-1}$ and $K_f = 1.86 \text{ K kg mol}^{-1}$ for water)
- (b) What would be the value of van't Hoff factor for a dilute solution of K_2SO_4 in water?
28. State differences between the following pairs :
- (i) α -helix structure and β -pleated sheet structure
- (ii) Primary and secondary structures of proteins
- (iii) Enzymes and co-enzymes

SECTION D

The following questions are case -based questions. Each question has an internal choice and carries 4(1 + 1 + 2) marks each. Read the passage carefully and answer the questions that follow.

29. A compound (X) containing C, H and O is unreactive towards sodium. It also does not react with Schiff's reagent. On refluxing with an excess of hydroiodic acid, (X) yields only one organic product (Y). On hydrolysis, (Y) yields a new compound (Z) which can be converted into (Y) by reaction with red phosphorus and iodine. The compound (Z) on oxidation with potassium permanganate gives a carboxylic acid. The equivalent weight of this acid is 60.

Answer the following questions :

- (a) To which class the compound (X) belongs to?

OR

Write the IUPAC name of the acid formed.

- (b) Identify the compound (Y).

(c) Give the structure and name of the product formed when compound (X) is treated with excess of Cl_2 in presence of light.

30. Elevation in boiling point is the increase in boiling point when a non-volatile solute is added to the solvent. Addition of the solute lowers the vapour pressure of solvent; hence more heat is required to increase the vapour pressure upto the atmospheric pressure. The addition of 3 g of a substance to 100 g CCl_4 ($M = 154 \text{ g mol}^{-1}$) raises the boiling point of CCl_4 by 0.60°C .

Given : $K_f(\text{CCl}_4) = 31.8 \text{ K kg mol}^{-1}$, $K_b(\text{CCl}_4)$ is $5.03 \text{ K kg mol}^{-1}$ and ρ (solution) = 1.64 g cm^{-3} .

Answer the following questions :

- (a) What will be the depression in freezing point of the solution?
- (b) Determine the molar mass of the substance.
- (c) Determine the relative lowering of vapour pressure of the solution.

OR

Define molal elevation constant for a solvent. Why is elevation of boiling point a colligative property?

SECTION E

The following questions are long answer type and carry 5 marks each. All questions have an internal choice.

31. Attempt any five of the following :

(a) $[\text{CoF}_6]^{3-}$ is paramagnetic but $[\text{Co}(\text{NH}_3)_6]^{3+}$ is diamagnetic complex. Why?

(b) Write the formula for the following coordination compounds :

Potassium trioxalatoaluminate(III)

(c) Write the coordination number and oxidation state of platinum in the complex $[\text{Pt}(\text{en})_2\text{Cl}_2]$.

(d) When a coordination compound $\text{CrCl}_3 \cdot 6\text{H}_2\text{O}$ is mixed with AgNO_3 , two moles of AgCl are precipitated per mole of the compound. What is the structural formula of coordination compound?

(e) Why is CO a stronger ligand than Cl^- ?

(f) Tetrahedral complexes are always of high spin. Explain.

(g) Explain homoleptic and heteroleptic complexes with example.

32. (i) How many moles of mercury will be produced by electrolysis of $1.0\text{M Hg}(\text{NO}_3)_2$ solution with a current of 2.00 A for 3 hours?

(ii) Calculate the cell emf at 25°C for the following cell : $\text{Mg}_{(s)}|\text{Mg}^{2+}(0.01\text{M}) \parallel \text{Sn}^{2+}(0.10\text{M})|\text{Sn}_{(s)}$

[Given: $E_{(\text{Mg}^{2+}/\text{Mg})}^a = -2.34\text{ V}$, $E_{(\text{Sn}^{2+})}^p = -0.136\text{ V}$, $1\text{ F} = 96500\text{ Cmol}^{-1}$].

Calculate the maximum work that can be accomplished by the operation of this cell.

OR

(a) (i) Express the relation between the conductivity (κ) and the molar conductivity (Λ_m) of a solution.

(ii) Electrolytic conductivity of 0.30M solution of KCl at 295 K is $3.72 \times 10^{-2} \text{ S cm}^{-1}$. Calculate the molar conductivity.

(b) (i) Solutions of two electrolytes 'A' and 'B' are diluted. It is found that Λ_m value of 'B' increases 2 times while that of 'A' increases 20 times. Which of the two is a strong electrolyte?

(ii) A galvanic cell has $E_{\text{cell}}^\circ = 1.1 \text{ V}$. If an opposing potential of 1.1 V is applied to this cell, what will happen to the cell reaction and current flowing through the cell?

(iii) How will the pH of brine solution be affected on electrolysis?

33. (a) Identify A to E in the following series of reactions.

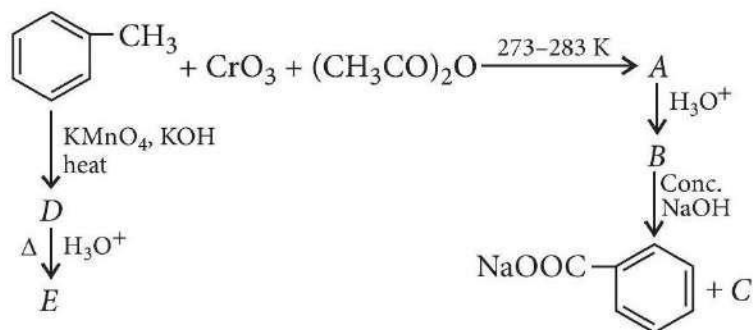

(b) Account for following:

(i) Chloroacetic acid has lower $\text{p}K_a$ value than acetic acid.

(ii) Electrophilic substitution in benzoic acid takes place at meta-position.

(iii) Carboxylic acids have higher boiling points than alcohol of comparable molecular masses.

OR

(a) How will you bring about the following conversions?

(i) Ethanal to but-2-enal

(ii) Propanone to propene

(b) Write the reactions involved in the following:

(i) Hell-Volhard-Zelinsky reaction

(ii) Decarboxylation reaction

SAMPLE PAPER

CHEMISTRY

CLASS 12

SET 03

CHEMISTRY

Time Allowed: 3 Hours

Maximum Marks: 70

General Instructions:

Read the following instructions carefully.

- (a) There are 33 questions in this question paper with internal choice.
- (b) SECTION A consists of 16 multiple-choice questions carrying 1 mark each.
- (c) SECTION B consists of 5 short answer questions carrying 2 marks each.
- (d) SECTION C consists of 7 short answer questions carrying 3 marks each.
- (e) SECTION D consists of 2 case-based questions carrying 4 marks each.
- (f) SECTION E consists of 3 long answer questions carrying 5 marks each.
- (g) All questions are compulsory.
- (h) Use of log tables and calculators is not allowed.

SECTION A

The following questions are multiple-choice questions with one correct answer. Each question carries 1 mark. There is no internal choice in this section.

1. An electric charge of 5 Faradays is passed through three electrolytes AgNO_3 , CuSO_4 and FeCl_3 solution. The grams of each metal liberated at cathode will be
 - (a) $\text{Ag} = 10.8 \text{ g}$, $\text{Cu} = 12.7 \text{ g}$, $\text{Fe} = 1.11 \text{ g}$
 - (b) $\text{Ag} = 540 \text{ g}$, $\text{Cu} = 367.5 \text{ g}$, $\text{Fe} = 325 \text{ g}$
 - (c) $\text{Ag} = 108 \text{ g}$, $\text{Cu} = 63.5 \text{ g}$, $\text{Fe} = 56 \text{ g}$
 - (d) $\text{Ag} = 540 \text{ g}$, $\text{Cu} = 158.8 \text{ g}$, $\text{Fe} = 93.3 \text{ g}$
2. Two isomeric compounds *A* and *B* have the formula $\text{C}_3\text{H}_6\text{Cl}_2$. With aq. KOH solution, *A* gives propionaldehyde and *B* gives acetone. Then *A* and *B* respectively are
 - (a) $\text{CH}_3 - \text{CCl}_2 - \text{CH}_3$ and $\text{CH}_3 - \text{CH}_2 - \text{CHCl}_2$
 - (b) $\text{CH}_3 - \text{CHCl} - \text{CH}_2\text{Cl}$ and $\text{CH}_3 - \text{CH}_2 - \text{CHCl}_2$
 - (c) $\text{CH}_3 - \text{CH}_2 - \text{CHCl}_2$ and $\text{CH}_3 - \text{CCl}_2 - \text{CH}_3$
 - (d) $\text{CH}_3 - \text{CHCl} - \text{CH}_2\text{Cl}$ and $\text{CH}_3 - \text{CCl}_2 - \text{CH}_3$

3. Match the column I with column II and mark the appropriate choice.

Column I		Column II	
(A)	An element which can show +8 oxidation state	(i)	Ce
(B)	Outer electronic configuration is $4f^76s^2$	(ii)	Pm
(C)	Radioactive lanthanoid	(iii)	Os
(D)	Lanthanoid which shows +4 oxidation state	(iv)	Eu

(a) (A) → (i), (B) → (ii), (C) → (iii), (D) → (iv)

(b) (A) → (ii), (B) → (iii), (C) → (iv), (D) → (i)

(c) (A) → (i), (B) → (iv), (C) → (ii), (D) → (iii)

(d) (A) → (iii), (B) → (iv), (C) → (ii), (D) → (i)

4. In three beakers labelled as (A), (B) and (C), 100 mL of water, 100 mL of 1M solution of glucose in water and 100 mL of 0.5M solution of glucose in water are taken respectively and kept at same temperature.

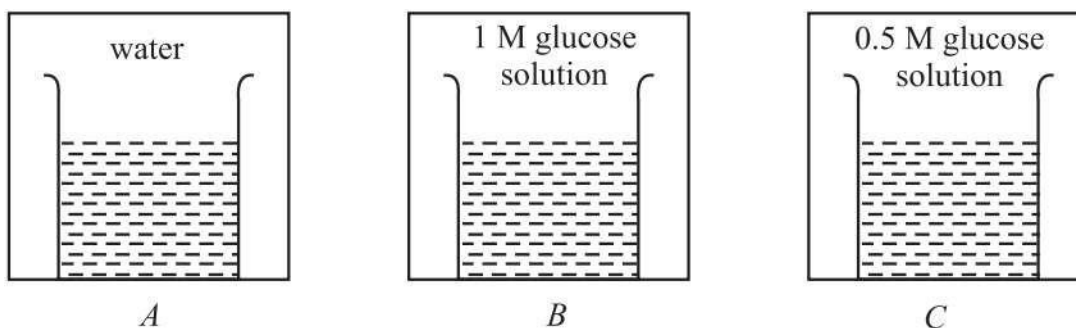

Which of the following statement is correct?

(a) Vapour pressure in all the three beakers is same.

(b) Vapour pressure of beaker B is highest.

(c) Vapour pressure of beaker C is highest.

(d) Vapour pressure of beaker B is lower than that of C and vapour pressure of beaker C is lower than that of A.

5.

Which one of the following is the most acidic compound?

(a)

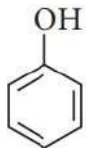

(b)

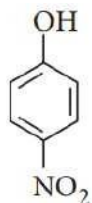

(c)

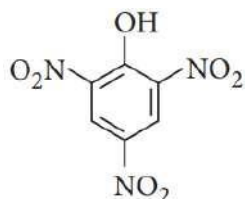

(d)

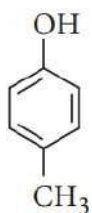

6. Which of the following pairs represents linkage isomers?

- (a) $[\text{Cu}(\text{NH}_3)_4][\text{PtCl}_4]$ and $[\text{Pt}(\text{NH}_3)_4][\text{CuCl}_4]$
- (b) $[\text{Pd}(\text{PPh}_3)_2(\text{NCS})_2]$ and $[\text{Pd}(\text{PPh}_3)_2(\text{SCN})_2]$
- (c) $[\text{Co}(\text{NH}_3)_5(\text{NO}_3)]\text{SO}_4$ and $[\text{Co}(\text{NH}_3)_5(\text{SO}_4)]\text{NO}_3$
- (d) $[\text{PtCl}_2(\text{NH}_3)_4]\text{Br}_2$ and $[\text{PtBr}_2(\text{NH}_3)_4]\text{Cl}_2$

7. Which of the following compounds will undergo self aldol condensation in the presence of cold dilute alkali?

- (a) $\text{CH} \equiv \text{C} - \text{CHO}$
- (b) $(\text{CH}_3)_3\text{CCHO}$
- (c) $\text{C}_6\text{H}_5\text{CHO}$
- (d) $\text{CH}_3\text{CH}_2\text{CHO}$

8. A binary liquid solution is prepared by mixing *n*-heptane and ethanol. Which one of the following statements is correct regarding the behaviour of the solution?
- The solution formed is an ideal solution.
 - The solution is non-ideal, showing +ve deviation from Raoult's law.
 - The solution is non-ideal, showing -ve deviation from Raoult's law.
 - n*-heptane shows +ve deviation while ethanol shows -ve deviation from Raoult's law.
9. A tripeptide (*X*) on partial hydrolysis gave two dipeptides *Cys – Gly* and *Glu-Cys*, i.e.,

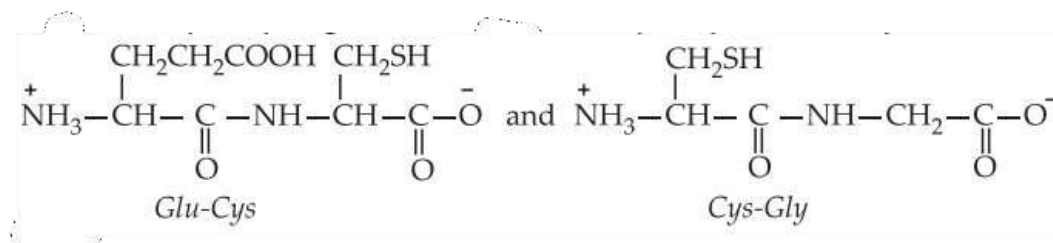

Identify the tripeptide.

- Glu-Cys-Gly
 - Gly-Glu-Cys
 - Cys-Gly-Glu
 - Cys-Glu-Gly
10. The activation energies of two reactions are E_1 and E_2 ($E_1 > E_2$). If the temperature of the system is increased from T_1 to T_2 , the rate constant of the reactions changes from k_1 to k_1' in the first reaction and k_2 to k_2' in the second reaction. Predict which of the following expression is correct?
- $\frac{k_1'}{k_1} = \frac{k_2'}{k_2}$
 - $\frac{k_1'}{k_1} > \frac{k_2'}{k_2}$
 - $\frac{k_1'}{k_1} < \frac{k_2'}{k_2}$
 - $\frac{k_1'}{k_1} = \frac{k_2'}{k_2} = 1$
11. Which of the following alcohols reacts most readily with Lucas reagent?
- $\text{CH}_3\text{CH}_2\text{CH}_2\text{OH}$
 - $$\begin{array}{c} \text{CH}_3 - \text{CH} - \text{CH}_3 \\ | \\ \text{OH} \end{array}$$
 -

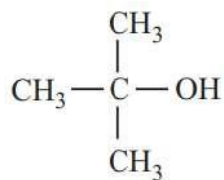

(d)

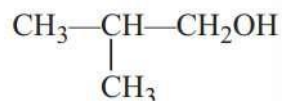

12. Hexaamminenickel(II) hexanitrocobaltate(III) can be written as

- (a) $[\text{Ni}(\text{NH}_3)_6]_2[\text{Co}(\text{NO}_2)_6]_3$
- (b) $[\text{Ni}(\text{NH}_3)_6]_3[\text{Co}(\text{NO}_2)_6]_2$
- (c) $[\text{Ni}(\text{NH}_3)_6][\text{Co}(\text{NO}_2)_6]$
- (d) $[\text{Ni}(\text{NH}_3)_6(\text{NO}_2)_6]\text{Co}$

13. Given below are two statements labelled as Assertion (A) and Reason (R).

Assertion (A) : Hoffmann degradation of benzamide gives aniline.

Reason (R) : Hoffmann bromamide degradation reaction can be used for descending amine series.

Select the most appropriate answer from the options given below:

- (a) Both A and R are true and R is the correct explanation of A.
- (b) Both A and R are true but R is not the correct explanation of A.
- (c) A is true but R is false.
- (d) A is false but R is true.

14. Given below are two statements labelled as Assertion (A) and Reason (R).

Assertion (A) : In acidic medium, $\text{K}_2\text{Cr}_2\text{O}_7$ exists as $\text{Cr}_2\text{O}_7^{2-}$ (orange) while in basic medium, it is converted to CrO_4^{2-} (yellow).

Reason (R) : $\text{K}_2\text{Cr}_2\text{O}_7$ is hygroscopic in nature and changes colour on reaction with water.

Select the most appropriate answer from the options given below:

- (a) Both A and R are true and R is the correct explanation of A.
- (b) Both A and R are true but R is not the correct explanation of A.
- (c) A is true but R is false.

(d) A is false but R is true.

15. Given below are two statements labelled as Assertion (A) and Reason (R).

Assertion (A) : Hydrolysis of sucrose brings about a change in sign of rotation from dextro to laevo.

Reason (R) : Hydrolysis always changes the optical rotation of a compound.

Select the most appropriate answer from the options given below:

(a) Both A and R are true and R is the correct explanation of A.

(b) Both A and R are true but R is not the correct explanation of A.

(c) A is true but R is false.

(d) A is false but R is true.

16. Given below are two statements labelled as Assertion (A) and Reason (R).

Assertion (A) : Boiling point of ethanol is higher than that of propane.

Reason (R) : Molecular mass of ethanol is higher than that of propane.

Select the most appropriate answer from the options given below:

(a) Both A and R are true and R is the correct explanation of A.

(b) Both A and R are true but R is not the correct explanation of A.

(c) A is true but R is false.

(d) A is false but R is true.

SECTION B

This section contains 5 questions with internal choice in one question. The following questions are very short answer type and carry 2 marks each.

17. Half-life period of first order reaction at 47°C is 10 minutes and at 27°C is 30 minutes. Calculate the activation energy of the reaction.

OR

(i) State a condition under which a bimolecular reaction is kinetically first order reaction.

(ii) For the reaction, $2A + B \rightarrow C$ if the order of the reaction is zero then what will be the relation between rate of reaction and rate constant?

18. The freezing point of a solution containing 50 cm³ of ethylene glycol in 50 g water is found to be -34°C. Assuming ideal behaviour, calculate the density of ethylene glycol. (K_f for H₂O = 1.86 K kg mol⁻¹)
19. Draw the structures of optical isomers of each of the following complex ions :
[PtCl₂(en)₂]²⁺, [Cr(NH₃)₂Cl₂(en)]⁺
20. Write the following conversions :
(i) Nitrobenzene → Acetanilide
(ii) Acetanilide → *p*-Nitroaniline
21. Explain why
(i) Alkyl halides, though polar, are immiscible with water.
(ii) Tertiary halides are least reactive towards S_N2 reactions.

SECTION C

This section contains 7 questions with internal choice in one question. The following questions are short answer type and carry 3 marks each.

22. (i) Based on solute-solvent interactions arrange the following in order of increasing solubility in *n*-octane and explain :
Cyclohexane, KCl, CH₃OH, CH₃CN
(ii) Two elements *A* and *B* form compounds having molecular formula *AB*₂ and *AB*₄. When dissolved in 20 g of benzene (C₆H₆), 1 g of *AB*₂ lowers the freezing point by 2.3 K whereas 1 g of *AB*₄ lowers it by 1.3 K. The molal depression constant for benzene is 5.1 K kg mol⁻¹. Calculate atomic masses of *A* and *B*.
23. (i) Out of (CH₃)₃C – Br and (CH₃)₃C – I, which one is more reactive towards S_N1 and why?
(ii) Write the product formed when *p*-nitrochlorobenzene is heated with aqueous NaOH at 443 K followed by acidification.
(iii) Why dextro and laevo-rotatory isomers of butan-2-ol are difficult to separate by fractional distillation?
24. (a) Name the reagents and write the chemical equations for the preparation of the following compounds by Williamson's synthesis :
(i) Ethoxybenzene
(ii) 2-Methyl-2-methoxypropane

- (b) Why do phenols not give the protonation reaction readily?
25. (a) What is the effect of substituents on basicity of amines?
 (b) Rearrange the following in an increasing order of their basic strengths :
 $\text{C}_6\text{H}_5\text{NH}_2$, $\text{C}_6\text{H}_5\text{N}(\text{CH}_3)_2$, $(\text{C}_6\text{H}_5)_2\text{NH}$ and CH_3NH_2
26. (a) The cell in which the following reaction occurs,

$$2\text{Fe}^{3+}_{(aq)} + 2\text{I}^{-}_{(aq)} \rightarrow 2\text{Fe}^{2+}_{(aq)} + \text{I}_{2(s)}$$
 has $E^\circ_{\text{cell}} = 0.236 \text{ V}$ at 298 K, calculate the standard Gibbs energy and the equilibrium constant of the cell reaction.
 (b) Λ_m° for NaCl, HCl and NaAc are 126.4, 425.9 and 91.0 $\text{S cm}^2 \text{ mol}^{-1}$ respectively. Calculate Λ° for HAc.
27. Write down functional isomers of a carbonyl compound with molecular formula $\text{C}_3\text{H}_6\text{O}$. Which isomer will react faster with HCN and why? Explain the mechanism of the reaction also. Will the reaction lead to the completion with the conversion of whole reactant into product at reaction conditions?
28. Answer the following questions (any 2):
 (a) What is "spectrochemical series"? What is the difference between a weak field ligand and a strong field ligand?
 (b) Why chelate complexes are more stable than complexes with unidentate ligands?
 (c) For the given complex $[\text{Fe}(\text{en})_2\text{Cl}_2]\text{Cl}$; write the name of the complex and also give oxidation number of iron.

SECTION D

The following questions are case -based questions. Each question has an internal choice and carries 4(1 + 1 + 2) marks each. Read the passage carefully and answer the questions that follow.

29. In a reaction, the rates of disappearance of different reactants or rates of formation of different products may not be equal but rate of reaction at any instant of time has the same value expressed in terms of any reactant or product. Further, the rate of reaction may not depend upon the stoichiometric coefficients of the balanced chemical equation. The exact powers of molar concentrations of reactants on which rate depends are found experimentally and expressed in terms of 'order of reaction.' Each reaction has a characteristic rate constant depends upon temperature. The units of the rate constant depend upon the order of reaction.
 Answer the following questions:
 (a) The rate constant of a reaction is found to be $3 \times 10^{-3} \text{ mol}^{-2} \text{ L}^2\text{sec}^{-1}$. What is the order of the reaction?

OR

Rate of a reaction can be expressed by following rate expression, $\text{Rate} = k[A]^2[B]$, if concentration of A is increased by 3 times and concentration of B is increased by 2 times, how many times rate of reaction increases?

(b) The rate of a certain reaction is given by, $\text{rate} = k[H^+]^n$. The rate increases 100 times when the pH changes from 3 to 1. What is the order (n) of the reaction?

(c) In a chemical reaction $A + 2B \rightarrow \text{products}$, when concentration of A alone is doubled, rate of the reaction increases 4 times and when concentration of B alone is doubled rate continues to be the same. What is the order of the reaction?

30. (A), (B) and (C) are three non-cyclic functional isomers of a carbonyl compound with molecular formula C_4H_8O . Isomers (A) and (C) give positive Tollens' test whereas isomer (B) does not give Tollens' test but gives positive iodoform test. Isomers (A) and (B) on reduction with $Zn(Hg)/\text{conc. HCl}$ give the same product (D).

Answer the following questions:

(a) What is the functional group present in compound (A)?

(b) Out of (A), (B) and (C) isomers, which one is least reactive towards addition of HCN ?

(c) Identify the compounds (A), (B), (C) and (D).

OR

What will be the product when (B) reacts with ethylene glycol in presence of HCl gas?

SECTION E

The following questions are long answer type and carry 5 marks each. All questions have an internal choice.

31. Attempt any five of the following:

(a) What is the basic structural difference between glucose and fructose?

(b) Write the structure of the product obtained when glucose is oxidised with nitric acid.

(c) What is meant by inversion of sugar?

(d) Explain glycosidic linkage by giving example.

(e) Which component of starch is a branched polymer of α -glucose and insoluble in water?

(f) Define polypeptide.

(g) What is the difference between α -form and β -form of glucose?

32. (a) (I) Complete the following reactions:

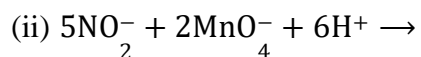

(II) Give two uses of KMnO_4 .

(b) CuI_2 is not known. Why?

(c) Second ionisation enthalpy for Cr and Cu is unusually high. Explain.

OR

Assign a reason for each of the following:

(i) Cr^{2+} is reducing and Mn^{3+} is oxidising in nature when both have d^4 configuration.

(ii) $[\text{Ti}(\text{H}_2\text{O})_6]^{3+}$ is purple coloured.

(iii) The transition metals (with the exception of Zn, Cd and Hg) are hard and have high melting and boiling points.

(iv) The ionisation enthalpies (first and second) in the first series of the transition elements are found to vary irregularly.

(v) Ce(IV) is a good analytical reagent.

33. (a) (i) What would happen if the protective tin coating over an iron bucket is broken in some place?

(ii) Why Λ_m° for acetic acid cannot be determined experimentally?

(b) The standard electrode potential for Daniell cell is 1.1 V. Calculate the standard Gibbs' energy for the reaction:

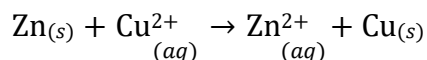

(c) The resistance of 0.01MNaCl solution at 25°C is 200 Ω . The cell constant of the conductivity cell used is unity. Calculate the molar conductivity of the solution.

OR

(a) At 291 K, molar conductivities at infinite dilution of NH_4Cl , NaOH , NaCl are 129.8, 217.4, 108.9 $\text{ohm}^{-1} \text{cm}^2$ respectively. If molar conductivity of normal solution of NH_4OH is 9.33 $\text{ohm}^{-1} \text{cm}^2$, what is the degree of dissociation of NH_4OH solution?

(b) The E° values corresponding to the following two reduction electrode processes are:

(i) $\text{Cu}^+/\text{Cu} = +0.52 \text{ V}$

(ii) $\text{Cu}^{2+}/\text{Cu}^+ = +0.16 \text{ V}$

Formulate the galvanic cell for their combination. What will be the standard cell potential for it? Calculate $\Delta_r G^\circ$ for the cell reaction. ($F = 96500 \text{ C mol}^{-1}$).

(c) What are fuel cells?

SAMPLE PAPER

CHEMISTRY

CLASS 12

SET 04
CHEMISTRY

Time Allowed: 3 Hours

Maximum Marks: 70

General Instructions:

Read the following instructions carefully.

- (a) There are 33 questions in this question paper with internal choice.
- (b) SECTION A consists of 16 multiple-choice questions carrying 1 mark each.
- (c) SECTION B consists of 5 short answer questions carrying 2 marks each.
- (d) SECTION C consists of 7 short answer questions carrying 3 marks each.
- (e) SECTION D consists of 2 case-based questions carrying 4 marks each.
- (f) SECTION E consists of 3 long answer questions carrying 5 marks each.
- (g) All questions are compulsory.
- (h) Use of log tables and calculators is not allowed.

SECTION A

The following questions are multiple-choice questions with one correct answer. Each question carries 1 mark. There is no internal choice in this section.

1. Which one of the following compounds is more reactive towards S_N1 reaction?
 - (a) $\text{CH}_2 = \text{CHCH}_2\text{Br}$
 - (b) $\text{C}_6\text{H}_5\text{CH}_2\text{Br}$
 - (c) $\text{C}_6\text{H}_5\text{CH}(\text{C}_6\text{H}_5)\text{Br}$
 - (d) $\text{C}_6\text{H}_5\text{CH}(\text{CH}_3)\text{Br}$
2. Which radioactive isotope would have the longer half-life ^{15}O or ^{19}O ? (Given rate constants (k) for ^{15}O and ^{19}O are $5.63 \times 10^{-3} \text{ s}^{-1}$ and $2.38 \times 10^{-2} \text{ s}^{-1}$ respectively.)
 - (a) ^{15}O
 - (b) ^{19}O
 - (c) Both will have the same half-life.

(X)

- (d) None of the above, information given is insufficient.
3. The oxidation of toluene to benzaldehyde by chromyl chloride is called
- Etard reaction
 - Riemer-Tiemann reaction
 - Stephen reaction
 - Cannizzaro reaction.
4. What will be the molality of a solution of glucose in water which is 10%w/W ?
- 0.01 m
 - 0.617 m
 - 0.668 m
 - 1.623 m
5. What is the molar conductance at infinite dilution for sodium chloride if the molar conductance at infinite dilution of Na^+ and Cl^- ions are $51.12 \times 10^{-4} \text{ S cm}^2/\text{mol}$ and $73.54 \times 10^{-4} \text{ S cm}^2/\text{mol}$ respectively?
- $124.66 \text{ S cm}^2/\text{mol}$
 - $22.42 \text{ S cm}^2/\text{mol}$
 - $198.20 \text{ S cm}^2/\text{mol}$
 - $175.78 \text{ S cm}^2/\text{mol}$
6. The major product of acid catalysed dehydration of 1-methylcyclohexanol is
- 1-methylcyclohexane
 - 1-methylcyclohexene
 - 1-cyclohexylmethanol
 - 1-methylenecyclohexane.
7. The CFSE of $[\text{CoCl}_6]^{3-}$ is 18000 cm^{-1} , the CFSE for $[\text{CoCl}_4]^-$ will be
- 18000 cm^{-1}
 - 8000 cm^{-1}
 - 2000 cm^{-1}
 - 16000 cm^{-1}
8. Which of the following is a non-reducing sugar?
- Glucose
 - Sucrose
 - Maltose
 - Lactose
9. Arrange the following in the increasing order of their boiling points :
- A : Butanamine, B: N, N-Dimethylethanamine, C: N-Ethylethanamine
- $C < B < A$
 - $A < B < C$
 - $A < C < B$
 - $B < C < A$

10. A 5% solution (w/W) of cane sugar (molar mass = 342 g mol^{-1}) has freezing point 271 K. What will be the freezing point of 5% glucose (molar mass = 18 g mol^{-1}) in water if freezing point of pure water is 273.15 K ?
- (a) 273.07 K
 (b) 269.07 K
 (c) 273.15 K
 (d) 260.09 K
11. α -Hydroxypropanoic acid can be prepared from ethanal by following the steps given in the sequence.
- (a) Treat with HCN followed by acidic hydrolysis.
 (b) Treat with NaHSO_3 followed by reaction with Na_2CO_3 .
 (c) Treat with H_2SO_4 followed by hydrolysis.
 (d) Treat with $\text{K}_2\text{Cr}_2\text{O}_7$ in presence of sulphuric acid.
12. The molar conductivity of CH_3COOH at infinite dilution is $390 \text{ S cm}^2/\text{mol}$. Using the graph and given information, the molar conductivity of CH_3COOK will be

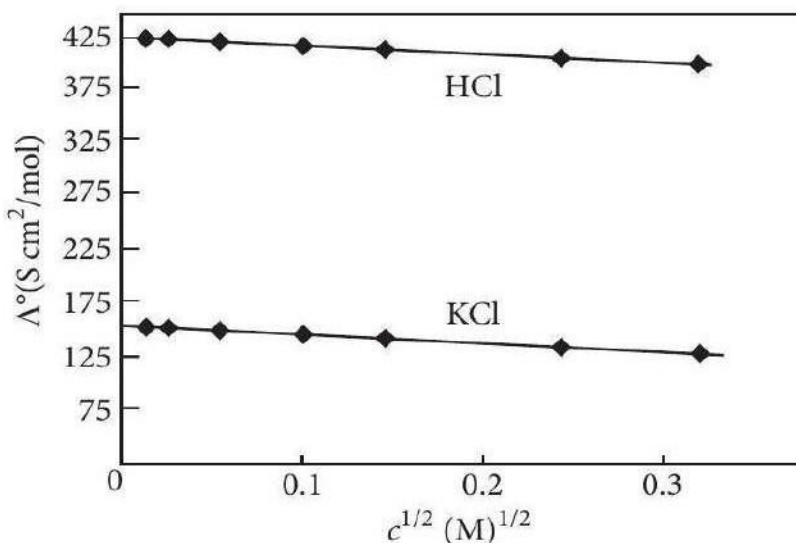

- (a) $100 \text{ S cm}^2/\text{mol}$
 (b) $115 \text{ S cm}^2/\text{mol}$
 (c) $150 \text{ S cm}^2/\text{mol}$
 (d) $125 \text{ S cm}^2/\text{mol}$
13. Given below are two statements labelled as Assertion (A) and Reason (R).
- Assertion (A) : Proteins are found to have two different types of secondary structures viz. alpha-helix and beta-pleated sheet structure.
- Reason (R) : The secondary structure of proteins is stabilized by hydrogen bonding.

Select the most appropriate answer from the options given below :

- (a) Both A and R are true and R is the correct explanation of A.
- (b) Both A and R are true but R is not the correct explanation of A.
- (c) A is true but R is false.
- (d) A is false but R is true.

14. Given below are two statements labelled as Assertion (A) and Reason (R).

Assertion (A) : Aromatic aldehydes and formaldehyde undergo Cannizzaro reaction.

Reason (R) : Those aldehydes which have α - H atom undergo Cannizzaro reaction.

Select the most appropriate answer from the options given below :

- (a) Both A and R are true and R is the correct explanation of A.
- (b) Both A and R are true but R is not the correct explanation of A.
- (c) A is true but R is false.
- (d) A is false but R is true.

15. Given below are two statements labelled as Assertion (A) and Reason (R).

Assertion (A) : $[\text{Co}(\text{NH}_3)_5\text{Br}]\text{SO}_4$ gives white precipitate with barium chloride.

Reason (R) : The given complex dissociates in the solution to give Br^- and SO_4^{2-} ions.

Select the most appropriate answer from the options given below:

- (a) Both A and R are true and R is the correct explanation of A.
- (b) Both A and R are true but R is not the correct explanation of A.
- (c) A is true but R is false.
- (d) A is false but R is true.

16. Given below are two statements labelled as Assertion (A) and Reason (R).

Assertion (A) : The rate of a reaction sometimes does not depend on concentrations.

Reason (R) : Lower the activation energy faster is the reaction.

Select the most appropriate answer from the options given below:

- (a) Both A and R are true and R is the correct explanation of A.

(b) Both A and R are true but R is not the correct explanation of A.

(c) A is true but R is false.

(d) A is false but R is true.

SECTION B

This section contains 5 questions with internal choice in one question. The following questions are very short answer type and carry 2 marks each.

17. Compare the basicity of the following compounds and arranged them in decreasing order.

(i) $\text{H}_2\text{C} = \text{CHCH}_2\text{NH}_2$

(ii) $\text{CH}_3\text{CH}_2\text{CH}_2\text{NH}_2$

(iii) $\text{HC} \equiv \text{CCH}_2\text{NH}_2$

18. (i) Why is freezing point depression of 0.1M sodium chloride solution nearly twice that of 0.1M glucose solution?

(ii) At 300 K, 36 g of glucose present per litre in its solution has an osmotic pressure of 4.98bar. If osmotic pressure of solution is 1.52 bar at the same temperature, what would be its concentration?

19. Write the reaction and IUPAC name of the product formed when 2-methylpropanal (isobutyraldehyde) is treated with ethyl magnesium bromide followed by hydrolysis.

20. Give reason for the following :

(a) During the electrophilic substitution reaction of haloarenes, para-substituted derivative is the major product.

(b) The product formed during S_N1 reaction is a racemic mixture.

21. Account for the following :

(a) There are five - OH groups in glucose.

(b) Glucose is a reducing sugar.

OR

What happens when *D*-glucose is treated with the following reagents?

(a) Bromine water

(b) HNO_3

SECTION C

This section contains 7 questions with internal choice in one question. The following questions are short answer type and carry 3 marks each.

22. (i) Write the structures of main products when benzenediazonium chloride ($C_6H_5 N_2Cl^-$) reacts with the following reagents :

- (a) BF_3/Δ
- (b) Cu/HBr

(ii) Write the structures of *A*, *B* and *C* in the following reactions :

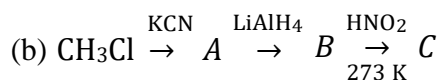
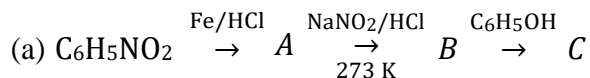

23. (a) Why does the cell voltage of a mercury cell remain constant during its lifetime?

(b) Write the reaction occurring at anode and cathode and the products of electrolysis of aq. NaCl.

(c) What is the pH of HCl solution when the hydrogen gas electrode shows a potential of -0.59 V at standard temperature and pressure?

24. (a) How are vitamins classified? Give examples.

(b) Name the vitamin whose deficiency causes

- (i) night blindness
- (ii) pernicious anaemia.

25. (a) State Henry's law and explain why are the tanks used by scuba divers are filled with air diluted with helium (11.7% helium, 56.2% nitrogen and 32.1% oxygen).

(b) Assume that argon exerts a partial pressure of 6 bar. Calculate the mol fraction of argon gas in water. (Given Henry's law constant for argon dissolved in water, $K_H = 40\text{kbar}$)

26. Answer the following questions (any 2) :

- (a) What is the effect of pH on dichromate ion solution?
- (b) Why Cu^+ ion is not stable in aqueous solution?
- (c) Why Scandium (at. no. 21) salts are white in colour?

27. (a) Identify the major product formed when 2-cyclohexylchloroethane undergoes a dehydrohalogenation reaction. Name the reagent which is used to carry out the reaction.

(b) Why are haloalkanes more reactive towards nucleophilic substitution reactions than haloarenes and vinylic halides?

(c) Write down the IUPAC name of the compound,

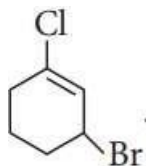

28. (a) Write a test to differentiate between pentan-2-one and pentan-3-one.

(b) Compound 'A' was prepared by oxidation of compound 'B' with alkaline KMnO_4 . Compound 'A' on reduction with lithium aluminium hydride gets converted back to compound 'B'. When compound 'A' is heated with compound 'B' in the presence of H_2SO_4 it produces fruity smell of compound 'C'. To which families the compounds 'A', 'B' and 'C' belong to?

SECTION D

The following questions are case-based questions. Each question has an internal choice and carries 4(1 + 1 + 2) marks each. Read the passage carefully and answer the questions that follow.

29. Most of the transition metal compounds are coloured due to the presence of incomplete d -subshell in transition metal ions.

In free isolated gaseous ion the five d orbitals are degenerate, i.e. they are identical in energy. In real life situations, the ion will be surrounded by solvent molecules if it is in solution; by other ligands if it is in a complex; or by other ions if it is in crystal lattice. The surrounding groups affect the energy of some d orbitals more than others. Thus the d orbitals are no longer degenerate, and they form two groups of orbitals of different energies. Thus in transition element ions with a partly filled d shell, it is possible to promote electrons from d level to another d level of higher energy. This corresponds to a fairly small energy difference and so light is absorbed in the visible region. The colour of a transition metal complex is dependent on how big the energy difference is between the two d levels. This in turn depends on the nature of the ligand, and on the type of complex formed. Thus the octahedral complex $[\text{Ni}(\text{NH}_3)_6]^{2+}$ is blue, $[\text{Ni}(\text{H}_2\text{O})_6]^{2+}$ is green and $[\text{Ni}(\text{NO}_2)_6]^{4-}$ is brown-red. The colour also depends on the number of ligands and the shape of the complex formed.

Answer the following questions :

(a) Copper(I) compounds are white whereas copper(II) compounds are coloured. Give reason.

OR

How would you account for the following :

Transition metals form coloured compounds?

(b) $\text{K}_2\text{Cr}_2\text{O}_7$ is orange coloured though Cr(VI) has d^0 configuration. Explain.

(c) Which of following cations are coloured in aqueous solutions and why?

Sc³⁺, V³⁺, Ti⁴⁺, Mn²⁺

(At. Nos. Sc = 21, V = 23, Ti = 22, Mn = 25)

30. Consider the following table of standard reduction potentials :

Reduction half reactions	E° values (V)
$A^{3+} + 2e^- \rightarrow A^+$	1.47
$B^{2+} + 2e^- \rightarrow B$	0.60
$C^{2+} + 2e^- \rightarrow C$	-0.21
$D^+ + e^- \rightarrow D$	-1.38

Answer the following questions :

- Name the strongest reducing agent.
- Name the substance(s) that can be oxidised by A^{3+} ions easily.
- Calculate the value of E° for the possible overall cell reaction that delivers the highest voltage.

OR

Name the substance(s) that can be oxidised by B^{2+} .

SECTION E

The following questions are long answer type and carry 5 marks each. All questions have an internal choice.

31. Attempt any five of the following:

- What will be the magnetic moment of complex, $Cs[FeCl_4]$?
- What is meant by chelate effect?
- Which of the following is more stable complex and why?

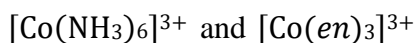

- $NH_2 \cdot NH_2$ although possesses two electron pairs for donation but does not act as chelating agent, why?
- Out of NH_3 and CO , which ligand forms a more stable complex with a transition metal and why?

(f) Arrange the following complexes in the increasing order of conductivity of their solution :

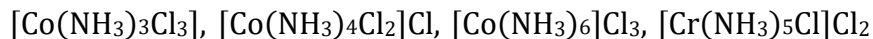

(g) What is the magnetic behaviour of the complex $[\text{Fe}(\text{en})_2\text{Cl}_2]\text{Cl}$?

32. An ether $A(\text{C}_5\text{H}_{12}\text{O})$ when heated with excess of hot concentrated HI produced two alkyl halides which on hydrolysis forms compounds B and C . Oxidation of B gives an acid D whereas oxidation of C gives a ketone E . Deduce the structures of A, B, C, D and E .

OR

Compound (A) gives positive Lucas test in 5 minutes. When 6.0 g of (A) is treated with Na metal, 1120 mL of H_2 is evolved at STP. Assuming (A) to contain one oxygen per molecule, write structural formula of (A). Compound (A) when treated with PBr_3 gives (B) which when treated with benzene in presence of anhydrous AlCl_3 gives (C). What are (B) and (C) ?

33. (a) A reaction is first order with respect to A and second order with respect to B .

(i) Write the differential rate equation.

(ii) How is the rate affected on increasing the concentration of B three times keeping concentration of A constant?

(iii) How is the rate affected when the concentrations of both A and B are doubled?

(b) With the help of an example explain what is meant by pseudo first order reaction.

OR

The initial rate of reaction :



has been determined by measuring the rate of disappearance of A under the following conditions :

Expt. No.	$[A]_0$ (M)	$[B]_0$ (M)	$[C]_0$ (M)	Initial rate (M min ⁻¹)
1.	0.02	0.02	0.02	2.08×10^{-3}
2.	0.01	0.02	0.02	1.04×10^{-3}
3.	0.02	0.04	0.02	4.16×10^{-3}

4.	0.02	0.02	0.04	8.32×10^{-3}
----	------	------	------	-----------------------

- (i) Determine the order of reaction with respect to each reactant.
- (ii) What is the rate constant?
- (iii) Calculate the initial rate of the reaction when the concentration of all the reactants is 0.01M.

SAMPLE PAPER

CHEMISTRY

CLASS 12

SET-05
CHEMISTRY

Time Allowed: 3 Hours

Maximum Marks: 70

General Instructions:

Read the following instructions carefully.

- (a) There are 33 questions in this question paper with internal choice.
- (b) SECTION A consists of 16 multiple-choice questions carrying 1 mark each.
- (c) SECTION B consists of 5 short answer questions carrying 2 marks each.
- (d) SECTION C consists of 7 short answer questions carrying 3 marks each.
- (e) SECTION D consists of 2 case-based questions carrying 4 marks each.
- (f) SECTION E consists of 3 long answer questions carrying 5 marks each.
- (g) All questions are compulsory.
- (h) Use of log tables and calculators is not allowed.

SECTION A

The following questions are multiple-choice questions with one correct answer. Each question carries 1 mark. There is no internal choice in this section.

1. What would be the reactant and reagent used to obtain 2,4-dimethylpentan-3-ol?
 - (a) Propanal and propyl magnesium bromide
 - (b) 3-Methylbutanal and 2-methyl magnesium iodide
 - (c) 2,2-Dimethylpropanone and methyl magnesium iodide
 - (d) 2-Methylpropanal and isopropyl magnesium iodide
2. KMnO_4 is coloured due to
 - (a) $d - d$ transitions
 - (b) charge transfer from ligand to metal
 - (c) unpaired electrons in d orbital of Mn
 - (d) charge transfer from metal to ligand.
3. The IUPAC name of the compound shown below is

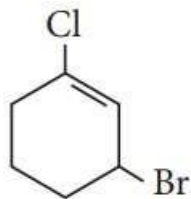

- (a) 2-bromo-6-chlorocyclohex-1-ene
- (b) 6-bromo-2-chlorocyclohexene
- (c) 3-bromo-1-chlorocyclohexene
- (d) 1-bromo-3-chlorocyclohexene.

4. A cell is set up as shown in the figure. It is observed that EMF of the cell comes out to be 2.36 V. Which of the given statements is not correct about the cell?

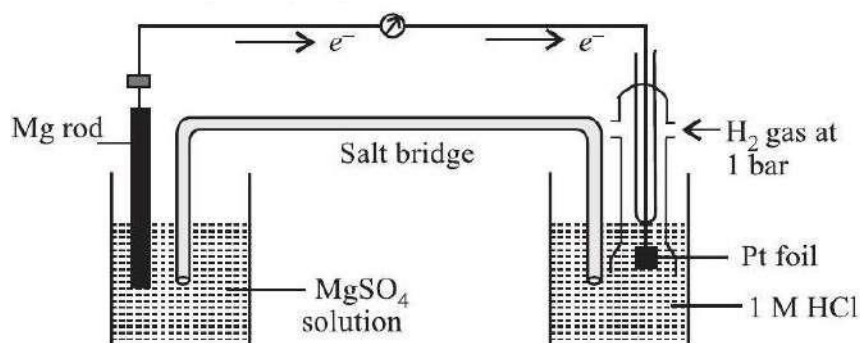

- (a) Reduction takes place at magnesium electrode and oxidation at SHE.
- (b) Oxidation takes place at magnesium electrode and reduction at SHE.
- (c) Standard electrode potential for $\text{Mg}^{2+} | \text{Mg}$ will be -2.36 V .
- (d) Electrons flow from magnesium electrode to hydrogen electrode.

5. The given graph shows the vapour pressure-temperature curves for some liquids.

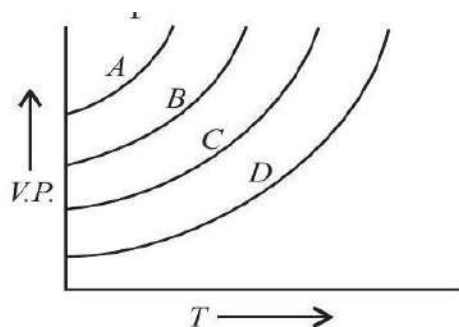

Liquids A, B, C and D respectively are

- (a) diethyl ether, acetone, ethyl alcohol, water
- (b) acetone, ethyl alcohol, diethyl ether, water
- (c) water, ethyl alcohol, acetone, diethyl ether
- (d) ethyl alcohol, acetone, diethyl ether, water.

6. Chlorination of toluene in presence of light and heat followed by treatment with aqueous NaOH gives
- o*-cresol
 - p*-cresol
 - 1,3,5-trihydroxytoluene
 - benzoic acid.
7. The absorption maxima of several octahedral complex ions are as follows:

S. No.	Compound	λ_{\max} (nm)
1.	$[\text{Co}(\text{NH}_3)_6]^{3+}$	475
2.	$[\text{Co}(\text{CN})_6]^{3-}$	310
3.	$[\text{Co}(\text{H}_2\text{O})_6]^{3+}$	490

The crystal field splitting is maximum for

- $[\text{Co}(\text{H}_2\text{O})_6]^{3+}$
 - $[\text{Co}(\text{CN})_6]^{3-}$
 - $[\text{Co}(\text{NH}_3)_6]^{3+}$
 - all the complex ions have the same splitting, Δ_o .
8. Compound $\text{C}_2\text{H}_6\text{O}$ has two isomers *X* and *Y*. On reaction with HI, *X* gives alkyl iodide and water while *Y* gives alkyl iodide and alcohol. Compounds *X* and *Y* are respectively
- $\text{C}_2\text{H}_5\text{OC}_2\text{H}_5$ and $\text{CH}_3\text{OC}_2\text{H}_5$
 - $\text{C}_2\text{H}_5\text{OH}$ and CH_3OCH_3
 - CH_3OCH_3 and $\text{C}_2\text{H}_5\text{OCH}_3$
 - CH_3OH and CH_3OCH_3
9. Study the structure of maltose and mark the incorrect statement.

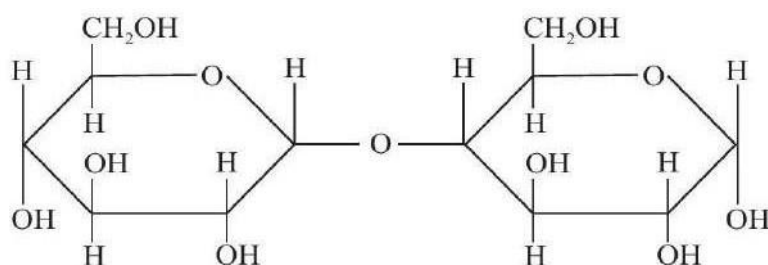

- Maltose is composed of two α - *D*-glucose units.
- C-1 of one glucose is linked to C-4 of other unit.
- It is a non-reducing sugar.
- It is a disaccharide.

10. Alkene (X) (C_5H_{10}) on ozonolysis gives a mixture of two compounds (Y) and (Z). Compound (Y) gives positive Fehling's test and iodoform test. Compound (Z) does not give Fehling's test but give iodoform test. Compounds (X), (Y) and (Z) are

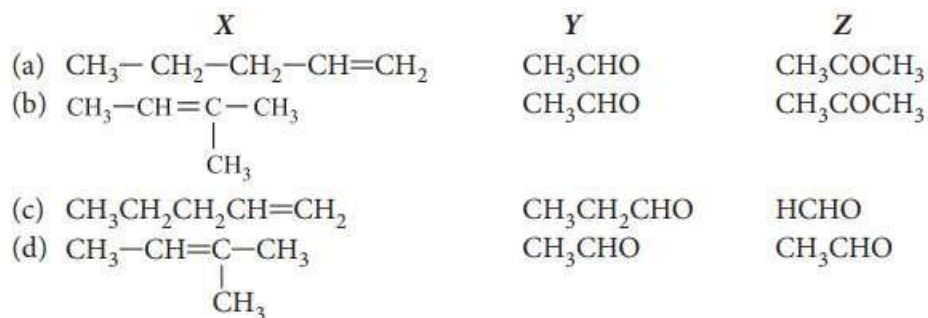

11. In the accompanied diagram the ideal behaviour of a solution is shown by the line(s)

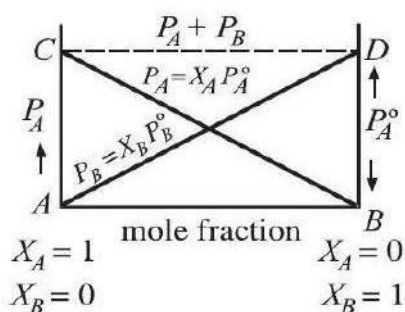

- (a) AD
 (b) CB
 (c) CD
 (d) AD, CB and CD
12. The two main differences between RNA and DNA are
 (a) ribose sugar and thymine in RNA
 (b) deoxyribose sugar and uracil in DNA
 (c) ribose sugar and uracil in RNA
 (d) deoxyribose sugar and guanine in DNA.

13. Given below are two statements labelled as Assertion (A) and Reason (R).

Assertion (A) : $[Fe(H_2O)_6]^{2+}$ is sp^3d^2 hybridised and paramagnetic complex ion.

Reason (R) : It has four unpaired electrons.

Select the most appropriate answer from the options given below:

- (a) Both A and R are true and R is the correct explanation of A.

(b) Both A and R are true but R is not the correct explanation of A.

(c) A is true but R is false.

(d) A is false but R is true.

14. Given below are two statements labelled as Assertion (A) and Reason (R).

Assertion (A) : Tertiary amines are more basic than corresponding secondary and primary amines in gaseous state.

Reason (R) : Tertiary amines have three alkyl groups which cause +I effect.

Select the most appropriate answer from the options given below:

(a) Both A and R are true and R is the correct explanation of A.

(b) Both A and R are true but R is not the correct explanation of A.

(c) A is true but R is false.

(d) A is false but R is true.

15. Given below are two statements labelled as Assertion (A) and Reason (R).

Assertion (A) : The magnetic properties of the actinoids are more complex than those of the lanthanoids.

Reason (R) : Actinide elements are strongly paramagnetic.

Select the most appropriate answer from the options given below:

(a) Both A and R are true and R is the correct explanation of A.

(b) Both A and R are true but R is not the correct explanation of A.

(c) A is true but R is false.

(d) A is false but R is true.

16. Given below are two statements labelled as Assertion (A) and Reason (R).

Assertion (A) : Glucose reacts with hydroxylamine to form an oxime and also adds a molecule of hydrogen cyanide to give cyanohydrin.

Reason (R) : The carbonyl group is present in the open chain structure of glucose.

Select the most appropriate answer from the options given below:

(a) Both A and R are true and R is the correct explanation of A.

(b) Both A and R are true but R is not the correct explanation of A.

(c) A is true but R is false.

(d) A is false but R is true.

SECTION B

This section contains 5 questions with internal choice in one question. The following questions are very short answer type and carry 2 marks each.

17. Draw one of the geometrical isomers of the complex $[\text{Pt}(\text{en})_2\text{Cl}_2]^{2+}$ which is optically inactive. Also write the name of this entity according to the IUPAC nomenclature.

18. The experimentally determined molar mass for what type of substances is always lower than the true value when water is used as solvent? Give one example of such a substance and one example of a substance which does not show a large variation from the true value.

19. Give reason for the following :

(a) Explain why the dipole moment of chlorobenzene is lower than that of cyclohexyl chloride.

(b) *n*-Butyl bromide has higher boiling point than *t*-butyl bromide.

20. (a) Give chemical tests to distinguish between the following pair of compounds :

Ethanal and Propanone.

(b) Arrange the following compounds in increasing order of their acid strength :

Benzoic acid, 4-Nitrobenzoic acid, 3,4-Dinitrobenzoic acid, 4-Methoxybenzoic acid.

OR

Compare the reactivity of benzaldehyde and ethanal towards nucleophilic addition reactions. Write the cross aldol condensation product between benzaldehyde and ethanal.

21. (a) In Kolbe's reaction, instead of phenol, phenoxide ion is treated with carbon dioxide. Why?

(b) What are the oxidation products of $(\text{CH}_3)_3\text{COH}$ using very strong oxidising agents?

SECTION C

This section contains 7 questions with internal choice in one question. The following questions are short answer type and carry 3 marks each.

22. Attempt the following questions (any 2) :

(a) Molar conductivity of substance 'A' is 5.9×10^3 S/m and 'B' is 1×10^{-16} S/m. Which of the two is most likely to be copper metal and why?

(b) What is the quantity of electricity in coulombs required to produce 4.8 g of Mg from molten MgCl_2 ? How much Ca will be produced if the same amount of electricity was passed through molten CaCl_2 ? (Atomic mass of Mg = 24u, atomic mass of Ca = 40u).

(c) What is the standard free energy change for the following reaction at room temperature? Is the reaction spontaneous?

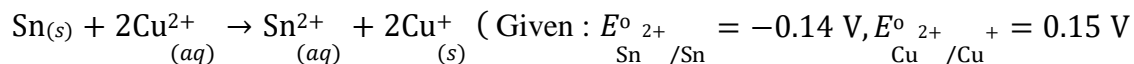

23. (a) How many geometrical isomers are possible in the following coordination entities?

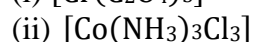
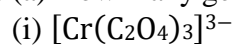

(b) Give the electronic configuration of the following complexes on the basis of crystal field splitting theory. $[\text{CoF}_6]^{3-}$ and $[\text{Cu}(\text{NH}_3)_6]^{2+}$.

24. A hydrocarbon (A) with molecular formula C_5H_{10} on ozonolysis gives two products (B) and (C). Both (B) and (C) give a yellow precipitate when heated with iodine in presence of NaOH while only (B) give a silver mirror on reaction with Tollen's reagent.

(a) Identify (A), (B) and (C).

(b) Write the reaction of B with Tollen's reagent.

(c) Write down the equation for aldol condensation reaction when two moles of B reacts with NaOH.

25. (a) What is meant by chirality of a compound? Give an example.

(b) Allyl chloride is more reactive than *n*-propyl chloride towards nucleophilic substitution reaction. Explain why.

(c) Which of the two compounds, $\text{CH}_3\text{CH}=\text{CHCH}_2\text{Br}$ or $\text{CH}_3\text{CH}(\text{Br})\text{CH}=\text{CH}_2$ is achiral and which is chiral?

26. Calculate the freezing point of a solution containing 0.5 gKCl (molar mass = 74.5 g/mol) dissolved in 100 g water, assuming KCl to be 92% ionized. (K_f of water = 1.86 K kg/mol).

27. Identify the product formed when propan-1-ol is treated with conc. H_2SO_4 at 413 K. Write the mechanism involved for the above reaction.

28. For the reaction $A + B \rightarrow$ products, the following initial rates were obtained at various given initial concentrations.

S.No.	[A] mol/ L	[B] mol / L	Initial rate M/s
1.	0.1	0.1	0.05

2.	0.2	0.1	0.10
3.	0.1	0.2	0.05

Determine the half-life period.

SECTION D

The following questions are case-based questions. Each question has an internal choice and carries 4(1 + 1 + 2) marks each. Read the passage carefully and answer the questions that follow.

29. A reaction is said to be unimolecular if, on the microscopic level, rearrangement of the structure of a single molecule produces the appropriate product molecules. An example of a unimolecular process is conversion of cis-2-butene to trans-2-butene (in the absence of any catalyst).

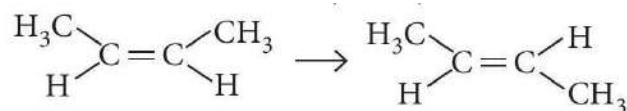

All that is required for this reaction to occur is a twist or rotation around the double bond interchanging the methyl group with the hydrogen atom on the right-hand side. Only one cis-2-butene molecule need to be involved as a reactant in this process. Rotating part of a molecule about a double bond is not easy, because it involves a distortion of the electron clouds forming the double bond. A considerable increase in energy is required to twist one end of cis-2-butene around the other. This is shown in figure.

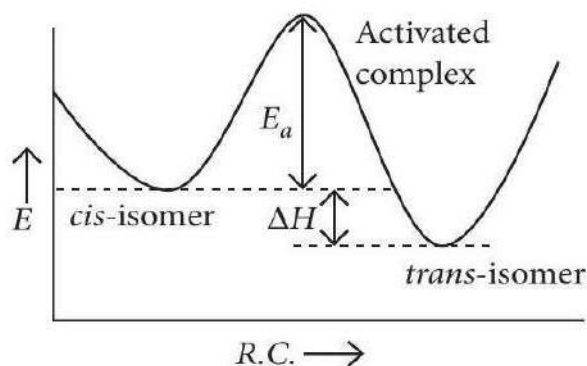

The minimum quantity of energy required to surmount an energy barrier during a chemical reaction is called the activation energy, E_a and the molecular species at the top of the barrier is called the activated complex or transition state.

In the sample of gaseous cis-2-butene at room temperature, only a tiny fraction of molecules have enough energy to surmount the activation energy barrier. Not only do few molecules have enough energy to overcome the activation energy barrier, but fewer still have that energy concentrated so that it can cause the atomic movements needed for the reaction to occur.

For a unimolecular process, the reaction rate must always be directly proportional to the concentration of the reacting species. For a general unimolecular process, $A \rightarrow \text{products}$, the rate equation is, $\text{Rate} = k[A]$, where $[A]$ = concentration of A .

Answer the following questions:

(a) With the help of given diagram, explain the activation energy (E_a) in chemical reactions.

OR

Can molecularity of a reaction be zero?

(b) Which factors can affect activation energy?

(c) Over a given period of time only a very small fraction of cis-2-butene molecule will be converted to trans-2-butene. Give reason.

30. Pentose and hexose undergo intramolecular hemiacetal or hemiketal formation due to combination of the $-\text{OH}$ group with the carbonyl group. The actual structure is either of five or six membered ring containing an oxygen atom. In the free state all pentoses and hexoses exist in pyranose form (resembling pyran). However, in the combined state some of them exist as five membered cyclic structures, called furanose (resembling furan).

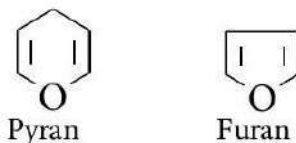

The cyclic structure of glucose is represented by Haworth structure:

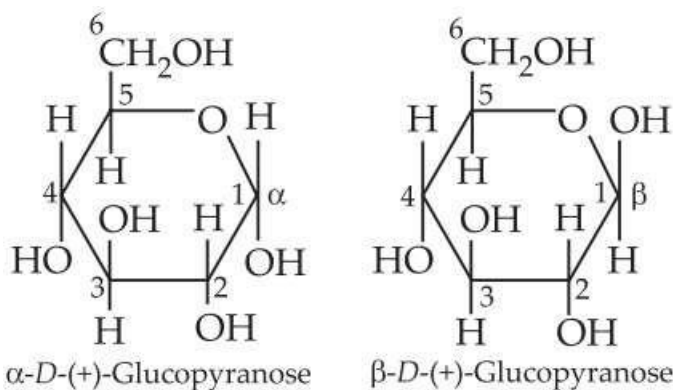

α - and β -D-glucose have different configuration at anomeric (C-1) carbon atom, hence are called anomers and the C – 1 carbon atom is called anomeric carbon (glycosidic carbon).

The six membered cyclic structure of glucose is called pyranose structure.

Answer the following questions :

(a) What is the difference between $\alpha - D(+)$ -glucose and $\beta - D(+)$ glucose ?

(b) The given carbohydrate is an α -furanose or a β -pyranose?

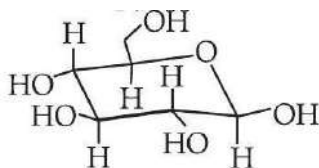

(c) What do you mean by anomers? Find anomeric carbon in given structure.

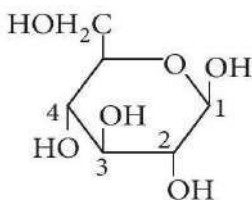

OR

Write the structural difference between starch and cellulose.

SECTION E

The following questions are long answer type and carry 5 marks each. All questions have an internal choice.

31. Attempt any five of the following :

(a) What is the effect of increasing pH on $K_2Cr_2O_7$ solution?

(b) What happens when potassium permanganate is heated strongly?

(c) The gradual decrease in size (actinoid contraction) from element to element is greater among the actinoids than among the lanthanoids (lanthanoid contraction). Give a reason.

(d) Why the d^1 configuration is very unstable in ions?

(e) Zr and Hf have almost similar atomic radii. Explain.

(f) What are inner transition elements?

(g) In what way are the observed oxidation states of the lanthanoids related to their electronic configuration?

32. An organic compound *A* with molecular formula C_7H_7NO reacts with $Br_2/aq. KOH$ to give compound *B*, which upon reaction with $NaNO_2$ and HCl at $0^\circ C$ gives *C*. Compound *C* on heating with CH_3CH_2OH gives a hydrocarbon *D*. Compound *B* on further reaction with Br_2 water gives white

precipitate of compound *E*. Identify the compound *A*, *B*, *C*, *D* and *E*; also justify your answer by giving relevant chemical equations.

OR

(a) How will you convert :

- (i) Aniline into Fluorobenzene.
- (ii) Benzamide into Benzylamine.
- (iii) Ethanamine to *N,N*-Diethylethanamine.

(b) Write the structures of *A* and *B* in the following:

(i)

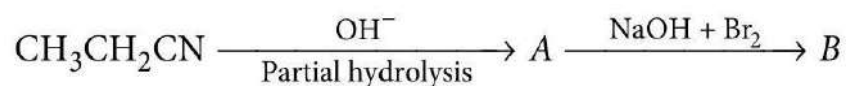

(ii)



33. (a) The e.m.f. of the following cell at 298 K is 0.1745 V

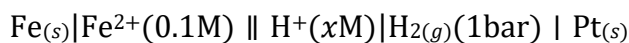

$$\text{Given : } E^\circ_{\text{Fe}^{2+}/\text{Fe}} = -0.44 \text{ V}$$

Calculate the H^+ ions concentration of the solution at the electrode where hydrogen is being produced.

(b) Aqueous solution of copper sulphate and silver nitrate are electrolysed by 1 ampere current for 10 minutes in separate electrolytic cells. Will the mass of copper and silver deposited on the cathode be same or different? Explain your answer.

OR

(a) Calculate the degree of dissociation of 0.0024M acetic acid if conductivity of this solution is $8.0 \times 10^{-5} \text{ S cm}^{-1}$.

$$\text{Given: } \lambda^\circ_{\text{H}^+} = 349.6 \text{ S cm}^2 \text{ mol}^{-1}; \lambda^\circ_{\text{CH}_3\text{COO}^-} = 40.9 \text{ S cm}^2 \text{ mol}^{-1}$$

(b) Solutions of two electrolytes '*A*' and '*B*' are diluted. The limiting molar conductivity of '*B*' increases to a smaller extent while that of '*A*' increases to a much larger extent comparatively. Which of the two is a strong electrolyte? Justify your answer.

SAMPLE PAPER

CHEMISTRY

CLASS 12

SET 06
CHEMISTRY

Time Allowed: 3 Hours

Maximum Marks: 70

General Instructions:

Read the following instructions carefully.

- (a) There are 33 questions in this question paper with internal choice.
- (b) SECTION A consists of 16 multiple-choice questions carrying 1 mark each.
- (c) SECTION B consists of 5 short answer questions carrying 2 marks each.
- (d) SECTION C consists of 7 short answer questions carrying 3 marks each.
- (e) SECTION D consists of 2 case-based questions carrying 4 marks each.
- (f) SECTION E consists of 3 long answer questions carrying 5 marks each.
- (g) All questions are compulsory.
- (h) Use of log tables and calculators is not allowed.

SECTION A

The following questions are multiple-choice questions with one correct answer. Each question carries 1 mark. There is no internal choice in this section.

1. Which of the following is most reactive towards aqueous NaOH ?
 - (a) C_6H_5Cl
 - (b) $C_6H_5CH_2Cl$
 - (c) C_6H_5Br
 - (d) BrC_6H_4Br
2. For Zn^{2+} , Ni^{2+} , Cu^{2+} and Cr^{2+} , which of the following statements is correct?
 - (a) Only Zn^{2+} is colourless and Ni^{2+} , Cu^{2+} and Cr^{2+} are coloured.
 - (b) All the ions are coloured.
 - (c) All the ions are colourless.
 - (d) Zn^{2+} and Cu^{2+} are colourless while Ni^{2+} and Cr^{2+} are coloured.

3. For a reaction $\frac{1}{2}A \rightarrow 2B$, rate of disappearance of A is related to rate of appearance of B by the expression

(a) $\frac{-d[A]}{dt} = \frac{1}{4} \frac{d[B]}{dt}$

(b) $\frac{-d[A]}{dt} = 4 \frac{d[B]}{dt}$

(c) $\frac{-d[A]}{dt} = \frac{1}{2} \frac{d[B]}{dt}$

(d) $\frac{-d[A]}{dt} = \frac{d[B]}{dt}$

4. Which of the following is not a characteristic of alcohol?

(a) They are lighter than water.

(b) Their boiling points rise fairly uniformly with rising molecular weight.

(c) Lower members are insoluble in water and organic solvents but the solubility regularly increases with molecular mass.

(d) Lower members have a pleasant smell and burning taste, higher members are colourless and tasteless.

5. Which of the following reactions will give benzophenone?

(i) Benzoyl chloride + Benzene + $AlCl_3$

(ii) Benzoyl chloride + Phenylmagnesium bromide

(iii) Benzoyl chloride + Diphenyl cadmium

(a) (i) and (ii) only

(b) (ii) and (iii) only

(c) (i) and (iii) only

(d) (i), (ii) and (iii)

6. Which of the following isomers will give white precipitate with $BaCl_2$ solution?

(a) $[Co(NH_3)_5SO_4]Br$

(b) $[Co(NH_3)_5Br]SO_4$

(c) $[Co(NH_3)_4(SO_4)_2]Br$

(d) $[Co(NH_3)_4Br(SO_4)]$

7. Write the structure of 'A' in the following reaction.

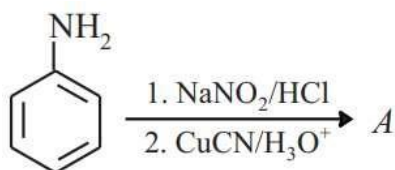

(a)

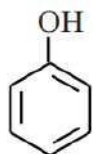

(b)

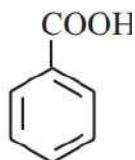

(c)

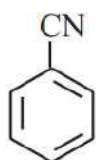

(d)

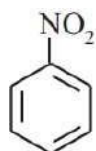

8. Which of the following is a reversible cell?

- (a) Dry cell
- (b) Mercury cell
- (c) Daniell cell
- (d) All of these.

9. Lanthanide contraction is the characteristic property of $4f$ -block elements which is associated with the increase in

- (a) atomic radius
- (b) shielding by $4f$ electrons
- (c) size of $4f$ orbitals
- (d) effective nuclear charge.

10. Ease of nucleophilic addition in the given compounds is

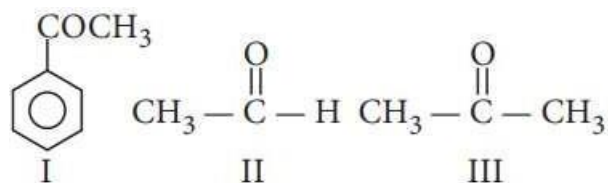

- (a) I > III > II
- (b) II > III > I
- (c) II > I > III
- (d) III > I > II

11. Chemical reaction proceeds following the formula $k = PZe^{-E_a/RT}$. Which of the following processes will increase the rate of reaction?

- (a) Lowering of E_a
- (b) Lowering of P
- (c) Lowering of Z
- (d) Rate of reaction is independent of all the above factors.

12. Which of the following will reduce Tollens' reagent?

- (a)

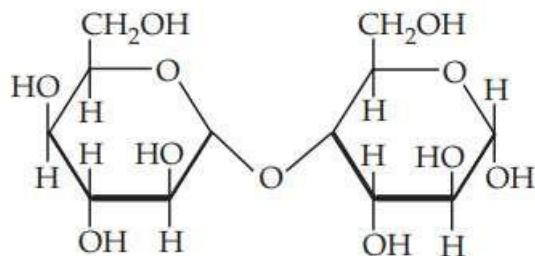

- (b)

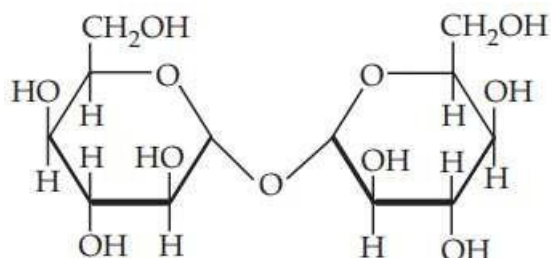

- (c) Both (a) and (b)
- (d) None of these.

13. Given below are two statements labelled as Assertion (A) and Reason (R).

Assertion (A) : When alkyl aryl ethers react with excess of hydrogen halides, phenol and alkyl halide are produced.

Reason (R) : Alkyl aryl ethers are cleaved at the alkyl-oxygen bond due to more stable aryl-oxygen bond.

Select the most appropriate answer from the options given below:

- (a) Both A and R are true and R is the correct explanation of A.
- (b) Both A and R are true but R is not the correct explanation of A.
- (c) A is true but R is false.
- (d) A is false but R is true.

14. Given below are two statements labelled as Assertion (A) and Reason (R).

Assertion (A) : DNA has a double helix structure.

Reason (R) : The two strands in a DNA molecule are exactly similar.

Select the most appropriate answer from the options given below:

- (a) Both A and R are true and R is the correct explanation of A.
- (b) Both A and R are true but R is not the correct explanation of A.
- (c) A is true but R is false.
- (d) A is false but R is true.

15. Given below are two statements labelled as Assertion (A) and Reason (R).

Assertion (A) : In high spin situation, configuration of d^5 ions will be $t_{2g}^3 e_g^2$.

Reason (R) : In high spin situation, pairing energy is less than crystal field energy.

Select the most appropriate answer from the options given below:

- (a) Both A and R are true and R is the correct explanation of A.
- (b) Both A and R are true but R is not the correct explanation of A.
- (c) A is true but R is false.
- (d) A is false but R is true.

16. Given below are two statements labelled as Assertion (A) and Reason (R).

Assertion (A) : *o*-Substituted benzoic acids are generally stronger acids than benzoic acids.

Reason (R) : Increased acidic strength is due to ortho-effect.

Select the most appropriate answer from the options given below:

- (a) Both A and R are true and R is the correct explanation of A.
- (b) Both A and R are true but R is not the correct explanation of A.
- (c) A is true but R is false.
- (d) A is false but R is true.

SECTION B

The section contains 5 questions with internal choice in one question. The following questions are very short answer type and carry 2 marks each.

17. Write the major product(s) in the following reactions :

(i)

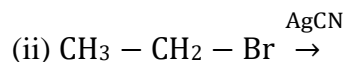
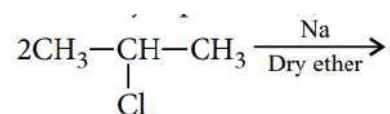

OR

Arrange each set of compounds in order of increasing boiling points :

- (i) Bromomethane, bromoform, chloromethane, dibromomethane
- (ii) 1-Chloropropane, iso-propyl chloride, 1-chlorobutane.

18. Account for the following :

- (i) The metallic radii of the third ($5d$) series of transition metals are virtually the same as those of the corresponding group member of the second ($4d$) series.
- (ii) The enthalpy of atomization is lowest for Zn in $3d$ -series of the transition elements.

19. For a certain chemical reaction variation of $\ln[R]$ vs. time (t) plot is given as :

(i) Predict the order of reaction from the given graph.

(ii) What does the slope of the line and intercept indicates?

20. (a) $C_5H_{13}N$ reacts with HNO_2 to give an optically active alcohol. What is the compound? Give its IUPAC name.

(b) Arrange the following compounds in the increasing order of dipole moment.



21. How are vitamins classified? Give examples.

SECTION C

This section contains 7 questions with internal choice in one question. The following questions are short answer type and carry 3 marks each.

22. Explain the following :

(i) Copper(I) ion is not known to exist in aqueous solutions.

(ii) Both O_2 and F_2 stabilize high oxidation states of transition metals but the ability of oxygen to do so exceeds that of fluorine.

(iii) Transition metals exhibit a wide range oxidation states.

23. A solution of $CuSO_4$ is electrolysed for 10 minutes with a current of 1.5 amperes. What is the mass of copper deposited at the cathode? ($F = 96487Cmol^{-1}$)

24. (a) Identify *A* and *B* in each of the following sequence:

(i)



(ii)

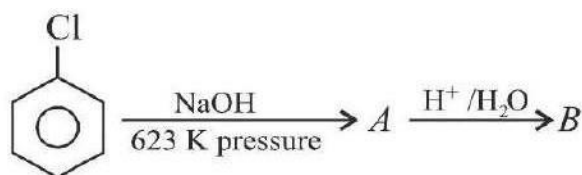

(b) Explain, why is ortho-nitrophenol more acidic than ortho-methoxyphenol.

25. Amino acids may be acidic, alkaline or neutral, how does this happen? What are essential and non-essential amino acids? Name one of each type.

26. Answer the following questions (any 2):

(i) Phenol associates in benzene to a certain extent to form a dimer. A solution containing 20 g of phenol in 1.0 kg of benzene has its freezing point lowered by 0.69 K. Calculate the fraction of phenol that has dimerised. [Given K_f for benzene = 5.1 K m^{-1}]

(ii) If N_2 gas is bubbled through water at 293 K, how many millimoles of N_2 gas would dissolve in 1 litre of water? Assume that N_2 exerts a partial pressure of 0.987 bar. Given that Henry's law constant for N_2 at 293 K is 76.48 kbar.

(iii) The vapour pressure of water is 12.3 kPa at 300 K. Calculate the vapour pressure of 1 molal solution of a solute in it.

27. (a) A solution contains 1 g mol each of *p*-toluene diazonium chloride and *p*-nitrophenyl diazonium chloride. To this 1 g mol of alkaline solution of phenol is added. Predict the major product. Explain your answer.

(b) Identify *A* and *B* in the following reaction:

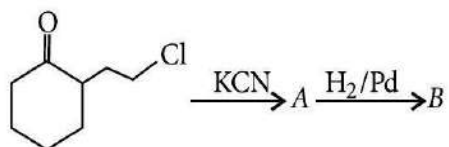

28. (i) For a reaction, $A + B \rightarrow \text{Product}$, the rate law is given by, $\text{Rate} = k[A]^1[B]^2$. What is the order of the reaction?

(ii) Write the unit of rate constant ' k ' for the first order reaction.

(iii) For the reaction $A \rightarrow B$, the rate of reaction becomes twenty seven times when the concentration of *A* is increased three times. What is the order of reaction?

SECTION D

The following questions are case-based questions. Each question has an internal choice and carries 4(1 + 1 + 2) marks each. Read the passage carefully and answer the questions that follow.

29. According to Raoult's law, the partial pressure of two components of the solution may be given as :

$$p_A = p_A^\circ x_A \text{ and } p_B = p_B^\circ x_B$$

For an ideal solution (obeys Raoult's law always)

$$\Delta H_{\text{mix}} = 0, \Delta V_{\text{mix}} = 0$$

All solutions do not obey Raoult's law over entire range of concentration. These are known as non-ideal solutions. For non-ideal solutions, $p_A \neq p_A^\circ x_A$ or $p_B \neq p_B^\circ x_B$

Positive deviation $\Rightarrow p_A > p_A^\circ x_A$ and $p_B > p_B^\circ x_B$

Negative deviation $\Rightarrow p_A < p_A^\circ x_A$ and $p_B < p_B^\circ x_B$

Answer the following questions:

(a) Give an example of solution showing positive deviation from ideal behaviour.

OR

What type of solution is formed when chloroform is mixed with acetone?

(b) What are the sign of ΔH and ΔV for a solution with positive deviation from ideal behaviour?

(c) The vapour pressure of pure water at 373 K is 760 mmHg while that of a dilute aqueous solution of glucose, $C_6H_{12}O_6$ is 750 mmHg at the same temperature. Calculate the mole fraction of the solute and molality of the solution.

(Atomic mass : C = 12.00, O = 16.00, H = 1.00amu)

30. Dehydration of alcohols can lead to the formation of either alkenes or ethers. This dehydration can be carried out either with protonic acids such as conc. H_2SO_4 , H_3PO_4 or catalysts such as anhydrous $ZnCl_2$ or Al_2O_3 . When primary alcohols are heated with conc. H_2SO_4 at 433 – 443 K, they undergo intramolecular dehydration to form alkenes. Secondary and tertiary alcohols undergo dehydration under milder conditions. The ease of dehydration of alcohols follows the order: $3^\circ > 2^\circ > 1^\circ$.

The dehydration of alcohols always occurs in accordance with the Saytzeff's rule. Primary alcohols when heated with protic acid at 413 K, gives dialkyl ether.

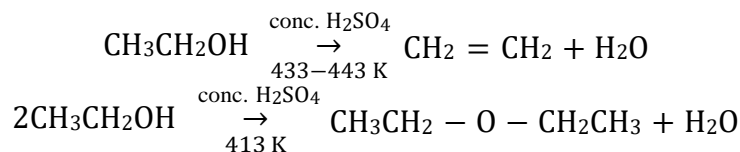

Answer the following questions:

(a) Dehydration of alcohol is an example of which type of reaction?

(b) Which of the following alcohol does not give a stable compound on dehydration?

- (I) ethyl alcohol
- (II) methyl alcohol
- (III) *n*-propyl alcohol
- (IV) *n*-butyl alcohol.

(c)

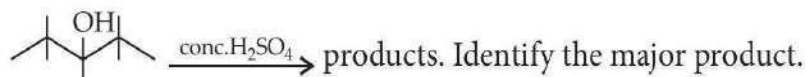

OR

The product of the reaction

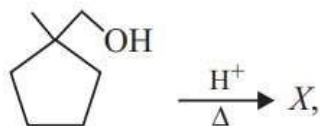

Identify X .

SECTION E

The following questions are long answer type and carry 5 marks each. All questions have an internal choice.

31. Attempt any five of the following.
- How much charge is required for the reduction of 1 mol of Zn^{2+} to Zn ?
 - Express the relation between the conductivity and the molar conductivity (Λ_m) of a solution.
 - What is limiting molar conductivity?
 - Which type of metal can be used in cathode protection of iron against rusting?
 - What is a fuel cell? Give the electrode reactions of hydrogen-oxygen fuel cell.
 - Express the relation among the conductivity of solution in the cell, the cell constant and the resistance of solution in the cell.
 - What would happen if the protective tin coating over an iron bucket is broken in some place?
32. (a) An organic compound with molecular formula $C_9H_{10}O$ forms 2,4-DNP derivative, reduces Tollens' reagent and undergoes Cannizzaro reaction. On vigorous oxidation, it gives 1,2-benzenedicarboxylic acid. Identify the compound.
- (b) A compound (A) $C_5H_8O_2$ liberates CO_2 on reaction with sodium bicarbonate. It exists in two forms neither of which is optically active. It yields (B) $C_5H_{10}O_2$ on hydrogenation. Compound (B) can be separated into two enantiomers. Write structural formulae for (A) and (B) with reason.

OR

An organic compound (A) of molecular weight 140.5 has 68.32% carbon, 6.4% hydrogen and 25.26% chlorine. Hydrolysis of (A) with dilute acid gives compound (B), $C_8H_{10}O$. Compound (B) can be oxidised under mild conditions to form compound (C), C_8H_8O . Compound (C) forms a phenylhydrazone (D) with phenylhydrazine and gives positive iodoform test. Deduce the structures of (A) to (D) with proper reasoning.

33. (a) Arrange the following complexes in the increasing order of conductivity of their solutions:
[Co(NH₃)₃Cl₃], [Co(NH₃)₄Cl₂]Cl, [Co(NH₃)₆]Cl₃, [Co(NH₃)₅Cl]Cl₂.
- (b) Why do compounds having similar geometry have different magnetic moment?
- (c) CuSO₄ · 5H₂O is blue in colour while CuSO₄ is colourless. Why?

OR

- (a) Why are different colours observed in octahedral and tetrahedral complexes for the same metal and same ligands?
- (b) What is the relationship between observed colour of the complex and the wavelength of light absorbed by the complex?
- (c) CoSO₄Cl · 5NH₃ exists in two isomeric forms 'A' and 'B'. Isomer 'A' reacts with AgNO₃ to give white precipitate, but does not react with BaCl₂. Isomer 'B' gives white precipitate with BaCl₂ but does not react with AgNO₃.
- (i) Identify 'A' and 'B' and write their structural formulae.
- (ii) Name the type of isomerism involved.
- (iii) Give the IUPAC name of 'A' and 'B'.

SAMPLE PAPER

CHEMISTRY

CLASS 12

SET-07
CHEMISTRY

Time Allowed: 3 Hours

Maximum Marks: 70

General Instructions:

Read the following instructions carefully.

- (a) There are 33 questions in this question paper with internal choice.
- (b) SECTION A consists of 16 multiple-choice questions carrying 1 mark each.
- (c) SECTION B consists of 5 short answer questions carrying 2 marks each.
- (d) SECTION C consists of 7 short answer questions carrying 3 marks each.
- (e) SECTION D consists of 2 case-based questions carrying 4 marks each.
- (f) SECTION E consists of 3 long answer questions carrying 5 marks each.
- (g) All questions are compulsory.
- (h) Use of log tables and calculators is not allowed.

SECTION A

The following questions are multiple-choice questions with one correct answer. Each question carries 1 mark. There is no internal choice in this section.

1. The correct order of boiling points of the following isomeric amines is $C_4H_9NH_2$, $(C_2H_5)_2NH$, $C_2H_5 N(CH_3)_2$
 - (a) $C_2H_5 N(CH_3)_2 > (C_2H_5)_2NH > C_4H_9NH_2$
 - (b) $(C_2H_5)_2NH > C_2H_5 N(CH_3)_2 > C_4H_9NH_2$
 - (c) $C_4H_9NH_2 > (C_2H_5)_2NH > C_2H_5 N(CH_3)_2$
 - (d) $(C_2H_5)_2NH > C_4H_9NH_2 > C_2H_5 N(CH_3)_2$

2.
$$\text{Glucose} \xrightarrow{\text{HCN}} X \xrightarrow{\text{Hydrolysis}} Y \xrightarrow[\text{Heat}]{\text{HI}} Z$$
. Identify Z.
 - (a) 2-Iodoheptane
 - (b) Heptane-2-ol
 - (c) 2-Iodohexane
 - (d) Heptanoic acid

3. For a reaction $X \rightarrow Y$, the rate of reaction becomes twenty seven times when the concentration of X is increased three times. What is the order of the reaction?

- (a) 2
- (b) 1
- (c) 3
- (d) 0

4. $E_{\text{Mn}^{3+}/\text{Mn}^{2+}}^{\circ}$ is highly positive than that of $E_{\text{Cr}^{3+}/\text{Cr}^{2+}}^{\circ}$ or $E_{\text{Fe}^{3+}/\text{Fe}^{2+}}^{\circ}$ because

- (a) $\text{Mn}^{2+}(d^5)$ can be easily oxidised to $\text{Mn}^{3+}(d^4)$ due to low ionisation enthalpy
- (b) third ionisation enthalpy of Mn is much larger due to stable half filled d^5 electronic configuration of Mn^{2+}
- (c) Mn^{3+} is more stable than Mn^{2+} due to higher oxidation state.
- (d) second ionisation enthalpy of Mn is higher than third ionisation enthalpy.

5. Which of the following reagents are not correctly matched with the reaction?

- (a) $\text{CH}_3\text{CH} = \text{CHCHO} \rightarrow \text{CH}_3\text{CH} = \text{CHCOOH}$: Ammonical AgNO_3
- (b) $\text{CH}_3\text{CH} = \text{CHCHO} \rightarrow \text{CH}_3\text{CH} = \text{CHCH}_2\text{OH}$: H_2/Pt
- (c) $\text{RCOOH} \rightarrow \text{RCH}_2\text{OH}$: LiAlH_4
- (d) $\text{CH}_3\text{CH}_2\text{COCl} \rightarrow \text{CH}_3\text{CH}_2\text{CHO}$: $\text{H}_2, \text{Pd}/\text{BaSO}_4$

6. Phenyl methyl ether (anisole) reacts with HI to give phenol and methyl iodide and not iodobenzene and methyl alcohol because

- (a) I^- ion prefers to combine with the smaller group in order to minimise steric hindrance
- (b) I^- ion is not reactive towards benzene
- (c) phenol is formed as a result of hydrolysis of iodobenzene
- (d) methyl alcohol formed during reaction reacts with I^- to form methyl iodide.

7. Consider the following statements with respect to lanthanides:

- (1) The basic strength of hydroxides of lanthanides increases from $\text{La}(\text{OH})_3$ to $\text{Lu}(\text{OH})_3$.
- (2) The lanthanide ions Lu^{3+} , Yb^{2+} and Ce^{4+} are diamagnetic.

Which of the statement(s) given above is/are correct?

- (a) 1 only
- (b) 2 only
- (c) Both 1 and 2
- (d) Neither 1 nor 2

8. The half-cell reactions with their appropriate standard reduction potentials are
 (i) $\text{Pb}^{2+} + 2e^- \rightarrow \text{Pb}$ ($E^\circ = -0.13 \text{ V}$)
 (ii) $\text{Ag}^+ + e^- \rightarrow \text{Ag}$ ($E^\circ = +0.80 \text{ V}$)

Based on the above data, which of the following reactions will take place?

- (a) $\text{Pb}^{2+} + 2\text{Ag} \rightarrow 2\text{Ag}^+ + \text{Pb}$
 (b) $2\text{Ag} + \text{Pb} \rightarrow 2\text{Ag}^+ + \text{Pb}^{2+}$
 (c) $2\text{Ag}^+ + \text{Pb} \rightarrow \text{Pb}^{2+} + 2\text{Ag}$
 (d) $\text{Pb}^{2+} + 2\text{Ag}^+ \rightarrow \text{Pb} + 2\text{Ag}$
9. Study the following sequence of reactions and identify the product (Y).

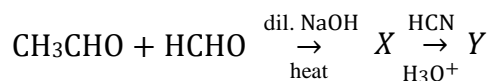

(a)

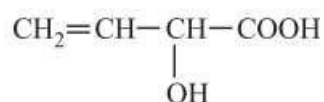

(b)

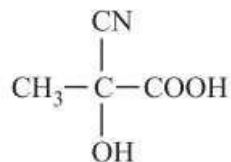

(c)

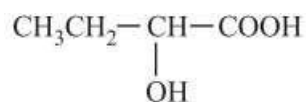

(d)

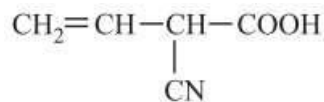

In the above reaction, the reactivity of alcohols is

- (a) tertiary > secondary > primary
 (b) tertiary < secondary < primary
 (c) tertiary > primary > secondary
 (d) secondary > primary > tertiary.
11. Which of the following reactions does not take place?

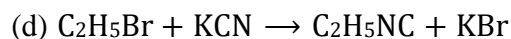
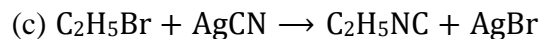
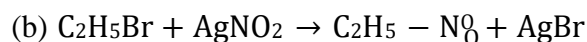
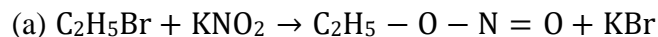

12. The half-life of the reaction $X \rightarrow Y$, following first order kinetics, when the initial concentration of A is 0.01 mol L^{-1} and initial rate is $0.00352 \text{ mol L}^{-1} \text{ min}^{-1}$ will be

- (a) 19.69 min
- (b) 1.969 min
- (c) 7.75 min
- (d) 77.5 min

13. Given below are two statements labelled as Assertion (A) and Reason (R).

Assertion (A): *D*-glucose is dextrorotatory whereas *L*-glucose is laevorotatory.

Reason (R): *D*-compounds are always dextro and *L*-compounds are always laevo.

Select the most appropriate answer from the options given below:

- (a) Both A and R are true and R is the correct explanation of A.
- (b) Both A and R are true but R is not the correct explanation of A.
- (c) A is true but R is false.
- (d) A is false but R is true.

14. Given below are two statements labelled as Assertion (A) and Reason (R).

Assertion (A): Current stops flowing when $E_{\text{cell}} = 0$.

Reason (R) : Equilibrium of the cell reaction is attained.

Select the most appropriate answer from the options given below:

- (a) Both A and R are true and R is the correct explanation of A.
- (b) Both A and R are true but R is not the correct explanation of A.
- (c) A is true but R is false.
- (d) A is false but R is true.

15. Given below are two statements labelled as Assertion (A) and Reason (R).

Assertion (A) : Ortho and para-nitrophenol can be separated by steam distillation.

Reason (R) : Para-nitrophenol is steam volatile due to intramolecular hydrogen bonding.

Select the most appropriate answer from the options given below:

- (a) Both A and R are true and R is the correct explanation of A.
- (b) Both A and R are true but R is not the correct explanation of A.
- (c) A is true but R is false.
- (d) A is false but R is true.

16. Given below are two statements labelled as Assertion (A) and Reason (R).

Assertion (A): $(\text{CH}_3)_3\text{CCOOH}$ does not give HVZ reaction.

Reason (R) : It does not have α -hydrogen atom.

Select the most appropriate answer from the options given below:

- (a) Both A and R are true and R is the correct explanation of A.
- (b) Both A and R are true but R is not the correct explanation of A.
- (c) A is true but R is false.
- (d) A is false but R is true.

SECTION B

This section contains 5 questions with internal choice in one question. The following questions are very short answer type and carry 2 marks each.

17. How will you distinguish 1° and 2° hydroxyl groups present in glucose? Explain with reactions.

18. (i) Write the isomers of $\text{C}_3\text{H}_5\text{Br}$ having

- (a) Br at vinylic position
- (b) Br at allylic position.

(ii) What is the advantage of using SOCl_2 in the preparation of R – Cl from alcohol?

19. Heptane and octane form ideal solution. At 373 K, the vapour pressures of the two liquid components are 105.2kPa and 46.8kPa, respectively. What will be the vapour pressure in bar of a mixture of 25.0 g of heptane and 35.0 g of octane?

20. For a chemical reaction, $R \rightarrow P$, the variation in the concentration $[R]$ vs. time (t) is given then

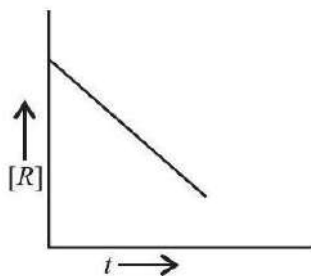

- (i) Predict the order of the reaction.
- (ii) What is the slope of the curve?
- (iii) Give one example of such type of reactions.

OR

- (i) For a reaction, $A + B \rightarrow \text{product}$, the rate law is given by, $\text{rate} = k[A]^1[B]^2$. What is the order of the reaction?
- (ii) Write the integrated rate expression and unit of rate constant ' k ' for the first order reaction.

21. Identify A , B and C in the following sequence of reactions:

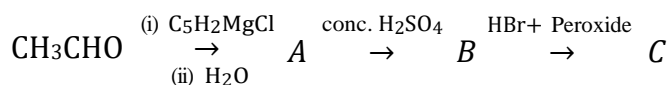

SECTION C

This section contains 7 questions with internal choice in one question. The following questions are short answer type and carry 3 marks each.

22. For the reaction, $2\text{NO} + \text{Cl}_2 \rightarrow 2\text{NOCl}$ at 300 K following data is obtained:

Expt. No.	Initial concentration (mol L^{-1})		Initial rate ($\text{mol L}^{-1}\text{s}^{-1}$)
	[NO]	[Cl ₂]	
1.	0.010	0.010	1.2×10^{-4}
2.	0.010	0.020	2.4×10^{-4}
3.	0.020	0.020	9.6×10^{-4}

Write rate law of the reaction. What is the order of the reaction? Also calculate the specific rate constant.

23. Give reason for the following:
- Amino acids behave like salts rather than simple amines or carboxylic acids.
 - Penta-acetate of glucose does not react with hydroxylamine.
 - The two strands in DNA are not identical but are complementary.
24. Answer the following questions (any 2):
- Write the chemical reaction involved in Wolff-Kishner reduction.
 - A* and *B* are two functional isomers of compound C_3H_6O . On heating with NaOH and I_2 , isomer *B* forms yellow precipitate of iodoform whereas isomer *A* does not form any precipitate. Write the formulae of *A* and *B*.
 - Write a test to differentiate between pentan-2-one and pentan-3-one.
25. $CoSO_4Cl \cdot 5NH_3$ exists in two isomeric forms '*A*' and '*B*'. Isomer '*A*' reacts with $AgNO_3$ to give white precipitate, but does not react with $BaCl_2$. Isomer '*B*' gives white precipitate with $BaCl_2$ but does not react with $AgNO_3$. Answer the following questions.
- Identify '*A*' and '*B*' and write their structural formulae.
 - Name the type of isomerism involved.
 - Give the IUPAC name of '*A*' and '*B*'.
26. How will you obtain the following:
- Ethanol from methanol
 - tert-Butyl alcohol from iso-butyl alcohol
 - Acetamide from ethyl alcohol?
27. (a) Allyl chloride is hydrolysed more readily than *n*-propyl chloride. Why?
(b) Why is it necessary to avoid even traces of moisture during the use of a Grignard reagent?
(c) Why is the solubility of haloalkanes in water very low?
28. An aqueous solution of $AuCl_3$ was electrolysed with a current of 0.5amp until 1.20 g of gold had been deposited on the cathode. At another electrode in series with this, the only reaction was the evolution of O_2 . Find
- number of moles of oxygen
 - the number of coulombs passed through the solution
 - the duration of electrolysis.

SECTION D

The following questions are case-based questions. Each question has an internal choice and carries 4(1 + 1 + 2) marks each. Read the passage carefully and answer the questions that follow.

29. A valence bond theory considers the bonding between the metal ion and the ligands as purely covalent. On the other hand, crystal field theory considers the metal-ligand bond to be ionic arising from electrostatic interaction between the metal ion and the ligands. In coordination compounds, the interaction between the ligand and the metal ion causes the five d -orbitals to split-up. This is called crystal field splitting and the energy difference between the two sets of energy level is called crystal field splitting energy. The crystal field splitting energy (Δ_o) depends upon the nature of the ligand. The actual configuration of complexes is divided by the relative values of Δ_o and P (pairing energy).
If $\Delta_o < P$, then complex will be high spin.
If $\Delta_o > P$, then complex will be low spin.

Answer the following questions:

- (a) $[\text{Ni}(\text{CO})_4]$ has tetrahedral geometry but it is diamagnetic. Give reason.

OR

$[\text{Mn}(\text{CN})_6]^{3-}$ has two unpaired electrons whereas $[\text{MnCl}_6]^{3-}$ has four unpaired electrons. Why?

(b) Tetrahedral complexes are always of high spin. Explain.

(c) Why $[\text{CoF}_6]^{3-}$ is outer orbital but $[\text{Co}(\text{NH}_3)_6]^{3+}$ is inner orbital complex?

30. The Gibbs free energy ΔG is the negative value of maximum electrical work, $\Delta G = -W = -q\Delta E$

A redox reaction equation represents definite amounts of reactants in the formation of definite amount of products. The number of electrons (n) in such a reaction equation is related to the amount of charge transferred when the reaction is completed. Since each mole of electron has a charge of 96500C (known as Faraday's constant, F)

$$\therefore q = nF \text{ and } \Delta G = -nF\Delta E^\circ, \text{ At standard conditions, } \Delta G^\circ = -nF\Delta E^\circ$$

The general Nernst equation correlates the Gibbs free energy ΔG and the EMF of a chemical system known as the Galvanic cell.

$$\text{For the reaction, } aA + bB \rightleftharpoons cC + dD \text{ and } Q = \frac{[C]^c [D]^d}{[A]^a [B]^b}$$

It has been shown that, $\Delta G = \Delta G^\circ + RT \ln Q$ and $\Delta G = -nF\Delta E$

$$\text{Therefore, } -nF\Delta E = -nF\Delta E^\circ + RT \ln Q$$

Thus we have, $\Delta E = \Delta E^\circ - \frac{RT}{nF} \ln \frac{[C]^c [D]^d}{[A]^a [B]^b}$

This is known as the Nernst equation.

The equation allows us to calculate the cell potential of any galvanic cell for any concentrations.

At 25°C, the Nernst equation becomes $\Delta E = \Delta E^\circ - \frac{0.0592}{n} \log \frac{[C]^c [D]^d}{[A]^a [B]^b}$

Answer the following questions:

(a) Calculate $\Delta_r G^\circ$ for the reaction:

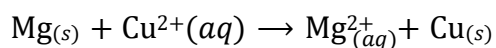

$$\text{Given } E^\circ_{\text{cell}} = +2.71 \text{ V}, 1 \text{ F} = 96500 \text{ C mol}^{-1}$$

(b) Calculate e.m.f. of the following cell at 298 K

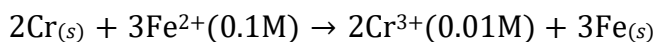

$$\text{Given : } E^\circ_{\text{(Cr}^{3+} | \text{Cr)}} = -0.74 \text{ V}, E^\circ_{\text{(Fe}^{2+} | \text{Fe)}} = -0.44 \text{ V}$$

(c) Determine the value of equilibrium constant (K_c) and ΔG° for the following reactions:

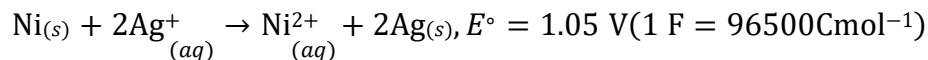

OR

A zinc rod is dipped in 0.1M solution of ZnSO_4 . The salt is 95% dissociated at this dilution at 298 K. Calculate the electrode potential.

$$[E^\circ_{\text{Zn}} / \text{Zn} = -0.76 \text{ V}]$$

SECTION E

The following questions are long answer type and carry 5 marks each. All questions have an internal choice.

31. Attempt any five of the following:

(a) What product is obtained when aniline reacts with concentrated sulphuric acid?

(b) What happens when aniline reacts with Br_2 water? Give reason.

(c) Identify *A* and *B* in the following sequence of reactions:

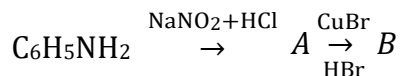

- (d) How is p-nitroaniline prepared from aniline?
- (e) Alkyl diazonium salts are highly unstable. Why?
- (f) Give a chemical test to distinguish between aniline and *N*-methylaniline. Give equation.
- (g) Lower aliphatic amines are soluble in water. Why?
32. (a) Describe the preparation of potassium permanganate from pyrolusite ore. Write the ionic equation for the reaction that takes place between acidified KMnO_4 solution and iron (II) ions.
- (b) Following are the transition metal ions of 3d series:

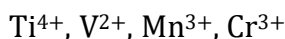

(Atomic numbers: Ti = 22, V = 23, Mn = 25, Cr = 24)

Answer the following:

- (i) Which ion is most stable in aqueous solution and why?
- (ii) Which ion is strong oxidising agent and why?
- (iii) Which ion is colourless and why?

OR

- (a) Name the oxo-metal anion of one of the transition metals in which the metal exhibits the oxidation state equal to the group number.
- (b) State a reason for each of the following situations:
- (i) Co^{2+} is easily oxidised to Co^{3+} in presence of a strong ligand.
- (ii) $E^0_{(M^{2+}/M)}$ value for copper is +ve.
- (c) How does the acidified potassium permanganate solution react with
- (i) iron(II) ions
- (ii) oxalic acid

Write the ionic equations for the reactions.

33. (a) Give the order of depression in freezing point of water for the same molar concentrations of acetic acid, trichloroacetic acid and trifluoroacetic acid. Give reason also.
- (b) Calculate the depression in freezing point of water when 20.0 g of $\text{CH}_3\text{CH}_2\text{CHClCOOH}$ is added to 500 g of water.

[Given: $K_a = 1.4 \times 10^{-3}$, $K_f = 1.86 \text{ K kg mol}^{-1}$]

OR

(a) Assuming complete dissociation, calculate the expected freezing point of a solution prepared by dissolving 6.00 g of Glauber's salt, $\text{Na}_2\text{SO}_4 \cdot 10\text{H}_2\text{O}$ in 0.100 kg of water.

(K_f for water = $1.86 \text{ K kg mol}^{-1}$, atomic masses of Na = 23, S = 32, O = 16, H = 1)

(b) Phenol associates in benzene to a certain extent to form a dimer. A solution containing 20 g of phenol in 1.0 kg of benzene has its freezing point lowered by 0.69 K. Calculate the fraction of phenol that has dimerised.

(Given: K_f for benzene = 5.1 K m^{-1})

SAMPLE PAPER

CHEMISTRY

CLASS 12

SET-08
CHEMISTRY

Time Allowed: 3 Hours

Maximum Marks: 70

General Instructions:

Read the following instructions carefully.

- (a) There are 33 questions in this question paper with internal choice.
- (b) SECTION A consists of 16 multiple-choice questions carrying 1 mark each.
- (c) SECTION B consists of 5 short answer questions carrying 2 marks each.
- (d) SECTION C consists of 7 short answer questions carrying 3 marks each.
- (e) SECTION D consists of 2 case-based questions carrying 4 marks each.
- (f) SECTION E consists of 3 long answer questions carrying 5 marks each.
- (g) All questions are compulsory.
- (h) Use of log tables and calculators is not allowed.

SECTION A

The following questions are multiple-choice questions with one correct answer. Each question carries 1 mark. There is no internal choice in this section.

1. Grapes placed in three beakers *X*, *Y* and *Z* containing different type of solutions are shown in figures.

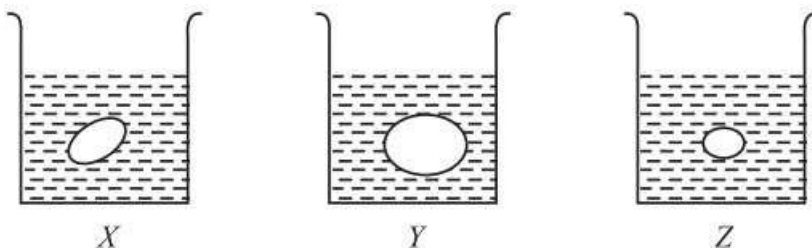

If beaker *X* contains water, *Y* and *Z* contain

- (a) *Y* - hypotonic solution, *Z* - hypertonic solution
- (b) *Y* - hypertonic solution, *Z* - hypotonic solution
- (c) *Y* and *Z* - isotonic solutions

(d) Y and Z - hypotonic solutions.

2. $[\text{Co}(\text{C}_2\text{O}_4)_3]^{3-}$ is a diamagnetic complex because
- (a) $\text{C}_2\text{O}_4^{2-}$ is strong field ligand hence causes pairing of electrons
 - (b) $\text{C}_2\text{O}_4^{2-}$ is a bidentate ligand hence causes pairing of electrons
 - (c) Co is a strong central atom hence in all complexes of Co electrons are paired.
 - (d) $\text{C}_2\text{O}_4^{2-}$ is a strong field ligand hence causes splitting of *d*-orbitals.

3. Consider the following statements:
- I. $\text{La}(\text{OH})_3$ is least basic among hydroxides of lanthanides.
 - II. Zr^{4+} and Hf^{4+} possess almost the same ionic radii.
 - III. Ce^{4+} can act as an oxidizing agent.

Which of the above is/are true?

- (a) I and III
 - (b) II and III
 - (c) II only
 - (d) I and II
4. Arrange the following alcohols in order of increasing reactivity towards sodium metal.
- (i) $(\text{CH}_3)_3\text{C} - \text{OH}$
 - (ii) $(\text{CH}_3)_2\text{CH} - \text{OH}$
 - (iii) $\text{CH}_3\text{CH}_2\text{OH}$
- (a) (iii) < (ii) < (i)
 - (b) (ii) < (i) < (iii)
 - (c) (i) < (ii) < (iii)
 - (d) (iii) < (i) < (ii)

5. Match the column I with column II and mark the appropriate choice.

Column I		Column II	
(A)	Nucleoside	(i)	Sugar + base + phosphoric acid group
(B)	Nucleotide	(ii)	Cytosine + uracil
(C)	DNA	(iii)	Sugar + base
(D)	RNA	(iv)	Cytosine + thymine

(a) (A) → (iii), (B) → (i), (C) → (iv), (D) → (ii)

(b) (A) → (i), (B) → (iv), (C) → (iii), (D) → (ii)

(c) (A) → (ii), (B) → (iii), (C) → (i), (D) → (iv)

(d) (A) → (iv), (B) → (ii), (C) → (i), (D) → (iii)

6. E_{cell}° for the reaction, $2\text{H}_2\text{O} \rightarrow \text{H}_3\text{O}^+ + \text{OH}^-$ at 25°C is -0.8277 V . The equilibrium constant for the reaction is

(a) 10^{-14}

(b) 10^{-23}

(c) 10^{-7}

(d) 10^{-21}

7. The end product (Q) in the following sequence of reactions is

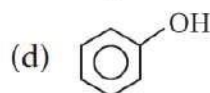
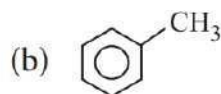
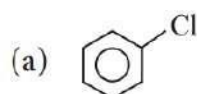
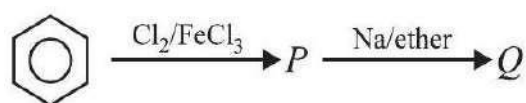

8. Propanone can be prepared from propyne by

(a) hydration of propyne in presence of HgSO_4 catalyst

(b) passing a mixture of propyne and ethanol over a catalyst zinc chromite

(c) boiling propyne with water and HNO_3

(d) treating propyne with iodine and NaOH .

9. Which of the following reagents can be used to convert acetamide into methanamine?

(a) P_2O_5

(b) NaOBr

(c) $\text{LiAlH}_4/\text{H}_2\text{O}$

(d) $\text{Na}(\text{Hg})/\text{C}_2\text{H}_5\text{OH}$

10. The decomposition of a hydrocarbon follows the equation $k = (4.5 \times 10^{11} \text{ s}^{-1})e^{-28000 \text{ K}/T}$. What will be the value of activation energy?

(a) 669 kJ mol^{-1}

(b) $232.79 \text{ kJ mol}^{-1}$

(c) $4.5 \times 10^{11} \text{ kJ mol}^{-1}$

(d) $28000 \text{ kJ mol}^{-1}$

11. The major product of acid catalysed dehydration of 2-methylcyclohexanol and butan-1-ol are respectively

- (a) 1-methylcyclohexene and but-1-ene
- (b) 2-methylcyclohexene and but-2-ene
- (c) 2-methylcyclohexene and butane
- (d) 1-methylcyclohexene and but-2-ene.

12. Which of the following energy level diagram for $[\text{FeF}_6]^{3-}$ is correct on the basis of crystal field theory?

(a)

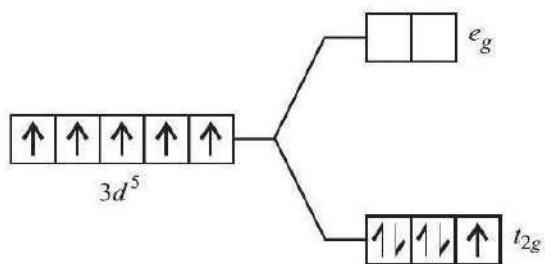

(b)

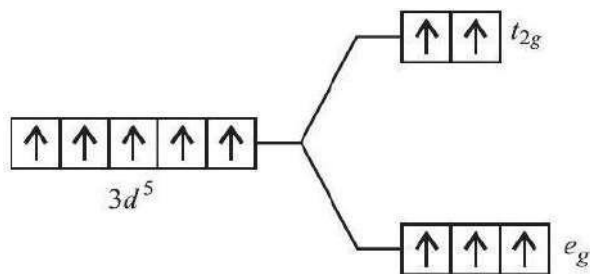

(c)

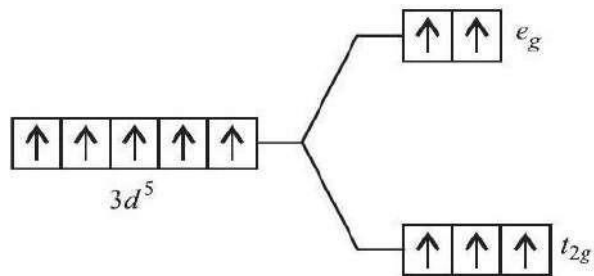

(d)

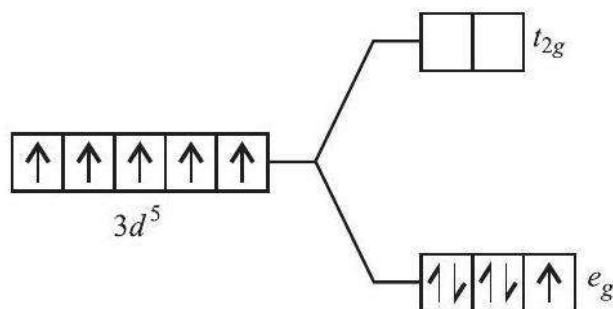

13. Given below are two statements labelled as Assertion (A) and Reason (R).

Assertion (A) : α -Amino acids are the building blocks of proteins.

Reason (R) : Natural amino acids are mostly α -amino acids.

Select the most appropriate answer from the options given below:

- (a) Both A and R are true and R is the correct explanation of A.
- (b) Both A and R are true but R is not the correct explanation of A.
- (c) A is true but R is false.
- (d) A is false but R is true.

14. Given below are two statements labelled as Assertion (A) and Reason (R).

Assertion (A) : The pressure exerted by a liquid at a given temperature is called its vapour pressure.

Reason (R) : If a non-volatile solute is added to a solvent to give a solution, the vapour pressure of the solution is found to be greater than the vapour pressure of the pure solvent.

Select the most appropriate answer from the options given below:

- (a) Both A and R are true and R is the correct explanation of A.
- (b) Both A and R are true but R is not the correct explanation of A.
- (c) A is true but R is false.
- (d) A is false but R is true.

15. Given below are two statements labelled as Assertion (A) and Reason (R).

Assertion (A) : *tert*-Butyl methyl ether on cleavage with HI at 373 K gives *tert*-butyl iodide and methanol.

Reason (R): The reaction occurs by S_N2 mechanism.

Select the most appropriate answer from the options given below:

- (a) Both A and R are true and R is the correct explanation of A.
- (b) Both A and R are true but R is not the correct explanation of A.
- (c) A is true but R is false.
- (d) A is false but R is true.

16. Given below are two statements labelled as Assertion (A) and Reason (R).

Assertion (A) : The maximum oxidation state of chromium in its compounds is +6 .

Reason (R) : Chromium has only six electrons in ns and $(n - 1)d$ orbitals.

Select the most appropriate answer from the options given below:

- (a) Both A and R are true and R is the correct explanation of A.
- (b) Both A and R are true but R is not the correct explanation of A.
- (c) A is true but R is false.
- (d) A is false but R is true.

SECTION B

This section contains 5 questions with internal choice in one question. The following questions are very short answer type and carry 2 marks each.

17. What would be the major product in each of the following reactions?

(i)

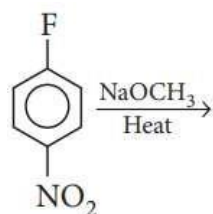

(ii)

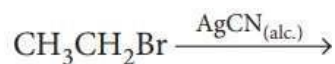

18. Upon heating a litre of a M/2HCl solution, 2.675 g hydrogen chloride is lost and the volume of the solution shrinks to 750 mL. Calculate the molarity of the resultant solution.

19. (i) Complete the following reaction:

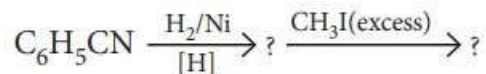

- (ii) What happens when an alkyl halide is treated with AgCN and product is hydrolysed?
20. (i) The reaction between $\text{H}_2(g)$ and $\text{O}_2(g)$ is highly feasible yet allowing the gases to stand at room temperature in the same vessel does not lead to the formation of water. Explain.
- (ii) Why does the rate of a reaction increase with rise in temperature?
21. Among $[\text{Ag}(\text{NH}_3)_2]\text{Cl}$, $[\text{NiCl}_4]^{2-}$ and $[\text{CuCl}_4]^{2-}$ which
- (a) has square planar geometry?
- (b) remains colourless in aqueous solution and why?

[Atomic number of Ag = 47, Ni = 28, Cu = 29]

OR

FeSO_4 solution mixed with $(\text{NH}_4)_2\text{SO}_4$ solution in 1:1 molar ratio gives the test of Fe^{2+} ion but CuSO_4 solution mixed with aqueous ammonia in 1:4 molar ratio does not give the test of Cu^{2+} ion. Explain why?

SECTION C

This section contains 7 questions with internal choice in one question. The following questions are short answer type and carry 3 marks each.

22. Give reasons for the following:
- (i) Cyclohexanone forms cyanohydrin in good yield but 2,4,6- trimethylcyclohexanone does not.
- (ii) Aldehydes are more reactive than ketones towards nucleophilic reagents.
- (iii) Benzamide is less easily hydrolysed than methyl benzoate.
23. Answer the following questions (any 2):
- (a) Write the reaction involved in the following:
- (i) Reimer-Tiemann reaction
- (ii) Friedel—Crafts alkylation of phenol
- (b) Write the product(s) of the following reactions:
- (i)

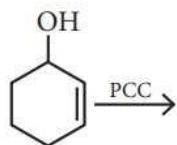

(ii)

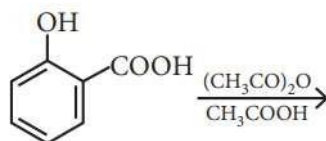

(c) Explain the following behaviours:

- (i) Alcohols are more soluble in water than the hydrocarbons of comparable molecular masses.
- (ii) Ortho-nitrophenol is more acidic than ortho-methoxyphenol.

24. (i) Predict the order of reactivity of the following compounds towards S_N1 reaction.

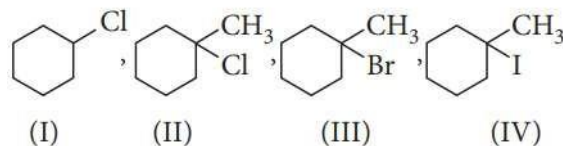

(ii) CHF_3 is less acidic than CHCl_3 . Explain.

25. A bottle of commercial sulphuric acid (density = 1.787 g/mL) is labelled as 86 percent by weight.

- (i) What is the molarity of the acid?
- (ii) What volume of the acid has to be used to make 1 L of 0.2M H_2SO_4 ?
- (iii) What is the molality of the acid?

26. (a) How is aniline obtained from benzene?

(b) Why are the secondary amines more basic than primary amines? Explain.

(c) Identify *A*, *B* and *C* in the following reactions:

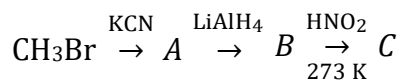

27. Write the IUPAC names of the following:

(a) $[\text{CoCl}(\text{NO}_2)(\text{NH}_3)_4]\text{Cl}$

(b) $[\text{PtCl}(\text{NH}_2\text{CH}_3)(\text{NH}_3)_2]\text{Cl}$

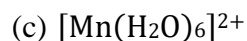

28. (a) Consider the following diagram in which an electrochemical cell is coupled to an electrolytic cell. What will be the polarity of electrodes 'A' and 'B' in the electrolytic cell?

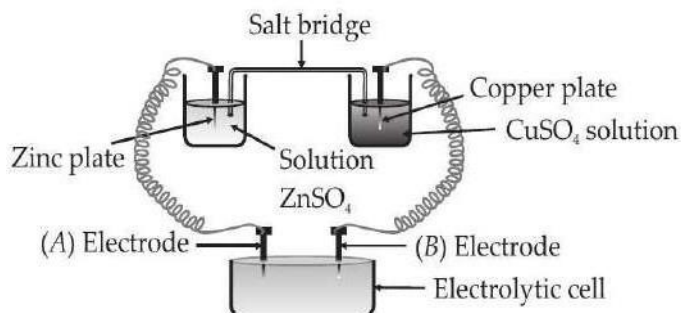

(b) How much charge is required for the following reductions:

- (i) 1 mol of Cu^{2+} to Cu ?
 (ii) 1 mol of MnO_4^- to Mn^{2+} ?

SECTION D

The following questions are case-based questions. Each question has an internal choice and carries 4(1 + 1 + 2) marks each. Read the passage carefully and answer the questions that follow.

29. Aldehydes and ketones having acetyl group ($\text{CH}_3 - \overset{\text{O}}{\parallel}{\text{C}} - \text{C}$) are oxidised by sodium hypohalite (NaOX) or halogen and alkali ($\text{X}_2 + \text{OH}^-$) to corresponding sodium salt having one carbon atom less than the carbonyl compound and give a haloform.

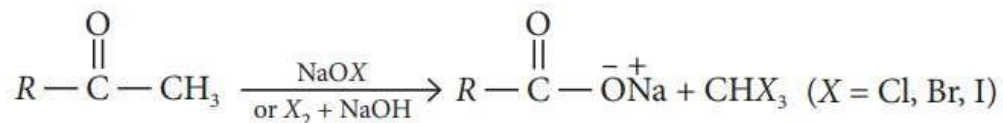

Sodium hypoiodite (NaOI) when treated with compounds containing CH_3CO - group gives yellow precipitate of iodoform. Haloform reaction does not affect a carbon-carbon double bond present in the compound.

Answer the following questions:

- (a) Out of isopropyl alcohol and propionaldehyde, which will give positive iodoform test?

OR

For the given set of reactions,

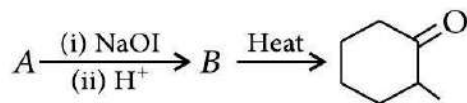

Identify compound A.

(b) An organic compound 'A' has the molecular formula C_3H_6O . It undergoes iodoform test. When saturated with HCl it gives 'B' of molecular formula $C_9H_{14}O$. Identify 'A' and 'B'.

(c) In the following reaction sequence, write the correct structures of E, F and G

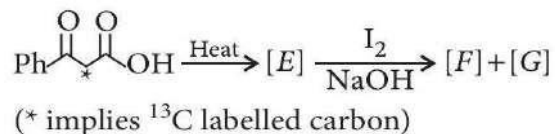

30. The half-life of a reaction is the time required for the concentration of reactant to decrease by half, i.e.,

$$[A]_t = \frac{1}{2} [A]$$

For first order reaction,

$$t_{1/2} = \frac{0.693}{k}$$

this means $t_{1/2}$ is independent of initial concentration. It may be noted that though the major portion of the first order kinetics may be over in a finite time, but the reaction will never cease as the concentration of reactant will be zero only at infinite time.

Answer the following questions:

(a) A first order reaction has a rate constant $k = 3.01 \times 10^{-3} \text{ s}^{-1}$. How long will it take to decompose half of the reactant?

(b) Draw the plot of $t_{1/2}$ vs initial concentration $[A]_0$ for a first order reaction.

(c) The rate constant for a first order reaction is $7.0 \times 10^{-4} \text{ s}^{-1}$. If initial concentration of reactant is 0.080M, what is the half life of reaction?

OR

The rate of a first order reaction is $0.04 \text{ mol L}^{-1} \text{ s}^{-1}$ after 10 minutes and $0.03 \text{ mol L}^{-1} \text{ s}^{-1}$ after 20 minutes of initiation. What is the half-life of reaction?

SECTION E

The following questions are long answer type and carry 5 marks each. All questions have an internal choice.

31. Attempt any five of all the following:

- (a) Amino acids show amphoteric behaviour. Why?
- (b) Why vitamin C cannot be stored in our body?
- (c) Sucrose is a non-reducing sugar. Why?
- (d) Write the name of the vitamin whose deficiency causes bleeding of gums.
- (e) Name two components of starch.
- (f) Name the products of hydrolysis of sucrose.
- (g) Which one of the following is a disaccharide: Starch, Maltose, Fructose, Glucose?

32. (a) Assign reason for each of the following:

- (i) Zn^{2+} salts are white while Cu^{2+} salts are coloured.
- (ii) The atomic radii decrease in size with the increasing atomic number in the lanthanoid series.
- (b) How do you account for the following?
 - (i) All scandium salts are white. (At. number of Sc = 21)
 - (ii) Third ionisation energy of manganese (At. number of Mn = 25) is unexpectedly high?
- (c) In which compounds transition metals show very low oxidation states?

OR

- (a) Why do the *d*-block elements exhibit a large number of oxidation states than the *f*-block elements?
- (b) How do the transition elements form interstitial compounds? State an industrial advantage of such occurrence.
- (c) Of the lanthanoid, only cerium (Ce = 58) is known to exhibit quite stable +4 state in solutions. Give reason.
- (d) Assign reasons for the following observations:
 - (i) Mn^{2+} compounds are more stable than Fe^{2+} compounds towards oxidation to their +3 state.

(ii) An aqueous solution of potassium chromate is yellow but changes its colour in decreasing the pH of the solution.

33. (a) How much electricity in terms of Faraday is required to produce

(i) 20.0 g of Ca from molten CaCl_2 ?

(ii) 40.0 g of Al from molten Al_2O_3 ?

(b) (i) What is Faraday?

(ii) Calculate the potential of hydrogen electrode in contact with a solution whose pH is 10.

OR

(a) Calculate standard emf of the cell in which following reaction takes place at 25°C .

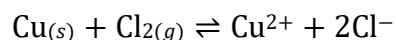

$$E^\circ_{\text{Cl}_2/\text{Cl}^-} = +1.36 \text{ V}, E^\circ_{\text{Cu}^{2+}/\text{Cu}} = +0.34 \text{ V}$$

(b) Also calculate standard free energy change and equilibrium constant of the reaction.

(c) The emf of a galvanic cell composed of two hydrogen electrode is 0.16 volt at 25°C . Calculate pH of the anode solution if the cathode is in a solution with $\text{pH} = 1$.

SAMPLE PAPER

CHEMISTRY

CLASS 12

SET-09
CHEMISTRY

Time Allowed: 3 Hours

Maximum Marks: 70

General Instructions:

Read the following instructions carefully.

- (a) There are 33 questions in this question paper with internal choice.
- (b) SECTION A consists of 16 multiple-choice questions carrying 1 mark each.
- (c) SECTION B consists of 5 short answer questions carrying 2 marks each.
- (d) SECTION C consists of 7 short answer questions carrying 3 marks each.
- (e) SECTION D consists of 2 case-based questions carrying 4 marks each.
- (f) SECTION E consists of 3 long answer questions carrying 5 marks each.
- (g) All questions are compulsory.
- (h) Use of log tables and calculators is not allowed.

SECTION A

The following questions are multiple-choice questions with one correct answer. Each question carries 1 mark. There is no internal choice in this section.

1. What are the correct steps to convert acetaldehyde to acetone?
 - (a) $\text{C}_2\text{H}_5\text{MgBr}$, H_2O , Oxidation
 - (b) Oxidation, $\text{Ca}(\text{OH})_2$, Heat
 - (c) Reduction, KCN, Hydrolysis
 - (d) Oxidation, $\text{C}_2\text{H}_5\text{ONa}$, Heat

2. Arrange the following alcohols in order of increasing reactivity towards sodium metal.
 - (i) $(\text{CH}_3)_3\text{C} - \text{OH}$
 - (ii) $(\text{CH}_3)_2\text{CH} - \text{OH}$
 - (iii) $\text{CH}_3\text{CH}_2\text{OH}$
 - (a) (iii) < (ii) < (i)
 - (b) (ii) < (i) < (iii)
 - (c) (i) < (ii) < (iii)
 - (d) (iii) < (i) < (ii)

3. Electrical conductance through metals is called metallic or electronic conductance and is due to the movement of electrons. The electronic conductance depends on
- the nature and structure of the metal
 - the number of valence electrons per atom
 - change in temperature
 - all of these.
4. The denticity of ethylenediaminetetraacetate ion is
- 4
 - 5
 - 6
 - none of these.
5. The empirical formula of a non-electrolyte is CH_2O . A solution containing 6 g of the compound exerts the same osmotic pressure as that of 0.05M glucose solution at the same temperature. The molecular formula of the compound is
- $\text{C}_2\text{H}_4\text{O}_2$
 - $\text{C}_3\text{H}_6\text{O}_3$
 - $\text{C}_5\text{H}_{10}\text{O}_5$
 - $\text{C}_4\text{H}_8\text{O}_4$

6. The end product (Q) in the following sequence of reactions is

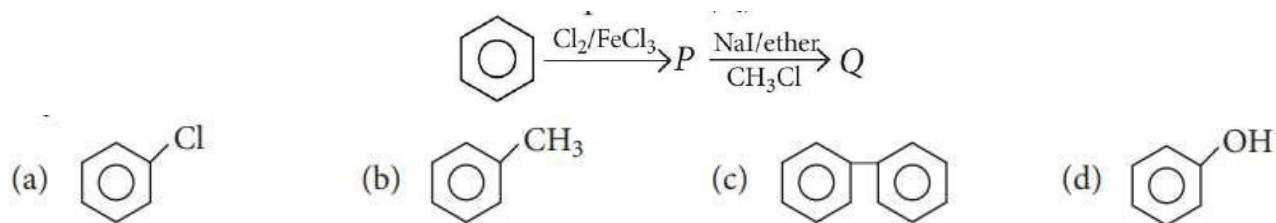

7. Which of the following tests/ reactions is given by aldehydes as well as ketones?
- Fehling's test
 - Tollens' test
 - 2,4-DNP test
 - Cannizzaro reaction
8. Which factor has no influence on the rate of reaction?
- Molecularity
 - Temperature
 - Concentration of reactant
 - Nature of reactant
9. Which of the following statements is not correct for amines?
- Most alkyl amines are more basic than ammonia solution.
 - $\text{p}K_b$ value of ethylamine is lower than benzylamine.

(c) CH_3NH_2 on reaction with nitrous acid releases NO_2 gas.

(d) Hinsberg's reagent reacts with secondary amines to form sulphonamides.

10. What will be the freezing point of a 0.5 mKCl solution? The molal freezing point constant of water is 1.86°Cm^{-1} .

- (a) -1.86°C
- (b) -0.372°C
- (c) -3.2°C
- (d) 0°C

11. Which of the following pair represents anomers?

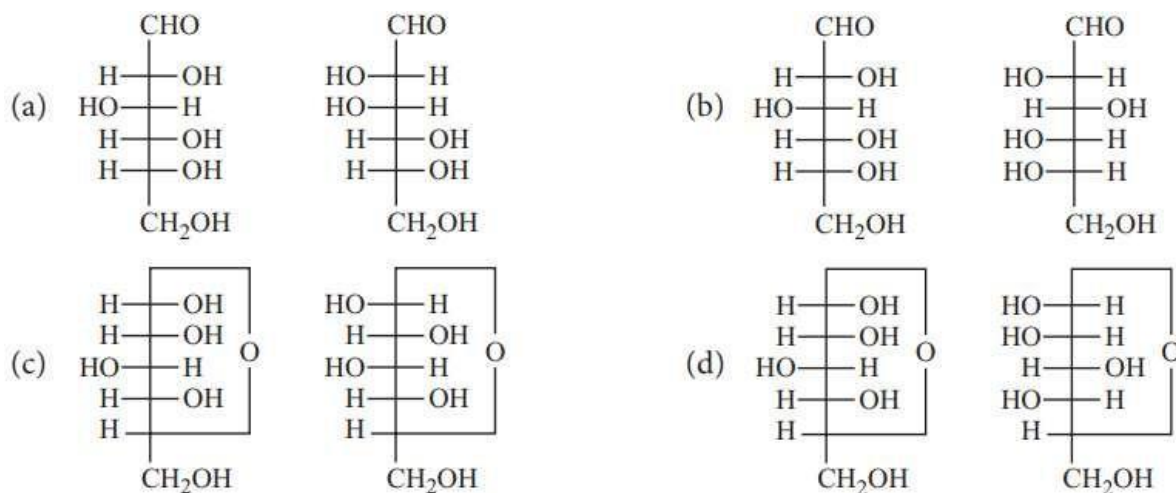

12. Arrhenius equation can be represented graphically as follows:

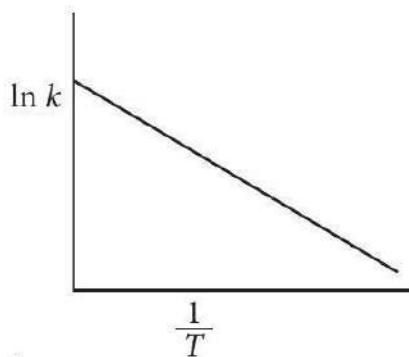

The (i) intercept and (ii) slope of the graph are

- (a) (i) $\ln A$ (ii) E_a/R
- (b) (i) A (ii) E_a
- (c) (i) $\ln A$ (ii) $-E_a/R$
- (d) (i) A (ii) $-E_a$

13. Given below are two statements labelled as Assertion (A) and Reason (R).

Assertion (A): The two strands in double strand helix structure of DNA are complementary to each other.

Reason (R): Disulphide bonds are formed between specific pairs of bases.

Select the most appropriate answer from the options given below:

- (a) Both A and R are true and R is the correct explanation of A.
- (b) Both A and R are true but R is not the correct explanation of A.
- (c) A is true but R is false.
- (d) A is false but R is true.

14. Given below are two statements labelled as Assertion (A) and Reason (R).

Assertion (A): Corrosion causes enormous damage to buildings, bridges, ships and to all objects made of metals.

Reason (R): Corrosion changes the chemical composition of metals.

Select the most appropriate answer from the options given below:

- (a) Both A and R are true and R is the correct explanation of A.
- (b) Both A and R are true but R is not the correct explanation of A.
- (c) A is true but R is false.
- (d) A is false but R is true.

15. Given below are two statements labelled as Assertion (A) and Reason (R).

Assertion (A): Catalytic reduction of butanal gives butanol.

Reason (R): Aldehydes on reduction give corresponding primary alcohols.

Select the most appropriate answer from the options given below:

- (a) Both A and R are true and R is the correct explanation of A.
- (b) Both A and R are true but R is not the correct explanation of A.
- (c) A is true but R is false.
- (d) A is false but R is true.

16. Given below are two statements labelled as Assertion (A) and Reason (R).

Assertion (A): $[\text{Ti}(\text{H}_2\text{O})_6]^{3+}$ is coloured while $[\text{Sc}(\text{H}_2\text{O})_6]^{3+}$ is colourless.

Reason (R): $d - d$ transition is not possible in $[\text{Sc}(\text{H}_2\text{O})_6]^{3+}$.

Select the most appropriate answer from the options given below:

- (a) Both A and R are true and R is the correct explanation of A.
- (b) Both A and R are true but R is not the correct explanation of A.
- (c) A is true but R is false.
- (d) A is false but R is true.

SECTION B

This section contains 5 questions with internal choice in one question. The following questions are very short answer type and carry 2 marks each.

17. On the basis of which evidences *D*-glucose was assigned the following structure?

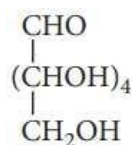

18. (i) Identify *A*, *B* and *C*.

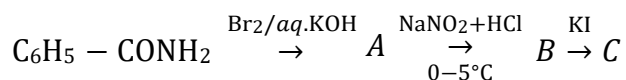

(ii) Give the decreasing order of reactivity for the following compounds towards coupling with $\text{PhN}_2^+\text{Cl}^-$.

- I. Toluene
- II. Nitrobenzene
- II. Chlorobenzene

19. (i) Identify the final product *B*.

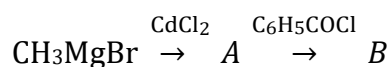

(ii) Identify *X* in the given reaction:

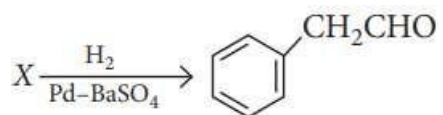

20. Which reaction, in each pair shown below, will show the faster rate of disappearance of starting material?

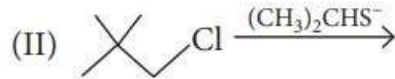
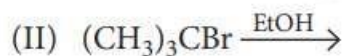
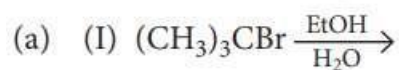

OR

Why is SOCl_2 (thionyl chloride) preferred for the preparation of alkyl chloride from alkyl alcohol?

21. Find the molality of a solution containing a non-volatile solute if the vapour pressure is 2% lower than the vapour pressure of pure water.

Chemistry

SECTION C

This section contains 7 questions with internal choice in one question. The following questions are short answer type and carry 3 marks each.

22. Although phenoxide ion has more number of resonating structures than carboxylate ion, carboxylic acid is a stronger acid than phenol. Why?

23. (a) What is osmotic pressure?

(b) A solution containing 4 g of a non-volatile organic solute per 100 cm^3 was found to have an osmotic pressure equal to 500 cmHg, at 27°C . Calculate the molar mass of the solute.

24. (a) Aromatic 1° amines cannot be prepared by Gabriel phthalimide reaction. Explain.

(b) Select the amine which is most reactive towards dil. HCl among the following. Explain.

CH_3NH_2 , $(\text{CH}_3)_2\text{NH}$, $(\text{CH}_3)_3\text{N}$, $\text{C}_6\text{H}_5\text{NH}_2$

25. Consider the figure and answer the questions (i) to (vi) given below:

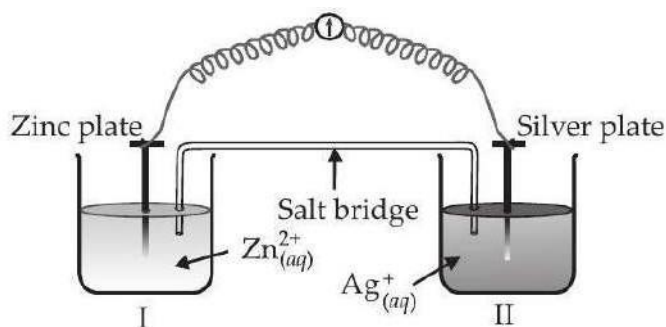

(i) Redraw the diagram to show the direction of electron flow.

- (ii) Does silver plate act as the anode or cathode?
- (iii) What will happen if salt bridge is removed?
- (iv) When will the cell stop functioning?
- (v) How will concentration of Zn^{2+} ions and Ag^+ ions be affected when the cell functions?
- (vi) How will the concentration of Zn^{2+} ions and Ag^+ ions be affected after the cell becomes 'dead'?

26. Give the plausible explanation for the following (any 2):

- (a) Glucose doesn't give 2,4-DNP test.
- (b) The two strands in DNA are not identical but are complementary.
- (c) Starch and cellulose both contain glucose unit as monomer, yet they are structurally different.

27. (a) Select the species with the highest melting point. Explain.

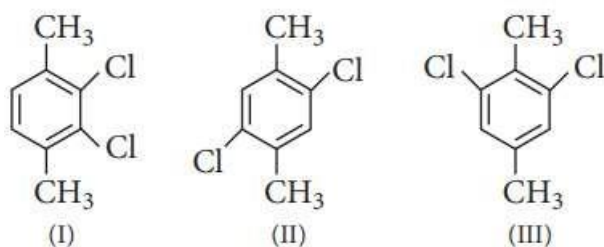

(b) Select the species that undergoes faster S_N1 reaction. Explain.

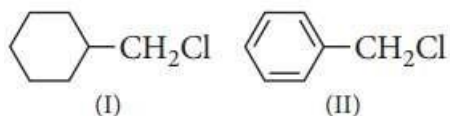

28. (a) The outer electronic configuration of two members of the lanthanoids are as follows: $4f^{15}d^16s^2$ and $4f^75d^06s^2$.

What are their atomic numbers? Predict the oxidation states exhibited by these elements in their compounds.

(b) Ionisation enthalpies of Ce, Pr and Nd are higher than Th, Pa and U. Why?

(c) Describe the variability of oxidation states in the first row of the transition elements (Sc – Cu) and indicate the general trend.

SECTION D

The following questions are case-based questions. Each question has an internal choice and carries 4(1 + 1 + 2) marks each. Read the passage carefully and answer the questions that follow.

29. The Edison storage cell is represented as: $\text{Fe}_{(s)}|\text{FeO}_{(s)}|\text{KOH}_{(aq)}|\text{Ni}_2\text{O}_{3(s)}|\text{Ni}_{(s)}$

The half-cell reactions are:

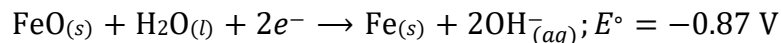

Answer the following questions:

(a) Write the cell reaction taking place at anode.

OR

What is the cell EMF?

(b) How does cell EMF depend on the concentration of KOH ?

(c) What is the maximum amount of electrical energy that can be obtained from one mole of Ni_2O_3 ?

30. The lanthanoid series is a unique class of 15 elements with relatively similar chemical properties.

They have atomic number ranging from 57 to 71, which corresponds to the filling of the 4*f* orbitals with 14 electrons. This configuration leads to phenomenon known as lanthanoid contraction. The lanthanoids are sometimes referred to as the 'rare earth elements', leading to misconception that they are rare. In fact, many of the rare earth elements are more common than gold, silver and in some cases, lead. The lanthanoids are commonly found in nature as a mixture in a number of monazite (LnPO_4) and bastnaesite ($\text{LnCO}_3 \cdot \text{F}$) in the +3 oxidation state.

The chemical and physical properties of lanthanoids provide the unique features that set them apart from other elements. Lanthanoids are most stable in the +3 oxidation state. Yb and Sm though stable in the +3 state, also have accessible +2 oxidation states. The ease of accessibility of both oxidation states is quite important in chemical synthesis and these elements act as Lewis acid in the +3 oxidation state and single electron reductant in the +2 oxidation state.

Answer the following questions:

(a) Name a member of the lanthanoid series which is well known to exhibit +2 oxidation state.

(b) Ce is used as an oxidising agent in volumetric analysis. Give reason.

(c) (i) How would you account for the following:

Among lanthanoids, Ln (III) compounds are predominant. However, occasionally in solutions or in solid compounds, +2 and +4 ions are also obtained.

(ii) Name a member of the lanthanoid series which is well known to exhibit +4 oxidation state.

OR

On the basis of Lanthanoid contraction, explain the following:

(i) Nature of bonding in La_2O_3 and Lu_2O_3 .

(ii) Radii of $4d$ and $5d$ elements.

SECTION E

The following questions are long answer type and carry 5 marks each. All questions have an internal choice.

31. Attempt any five of the following:

(a) Name the starting material used in the industrial preparation of phenol.

(b) Write complete reaction for the bromination of phenol in aqueous and non-aqueous medium.

(c) Explain why Lewis acid is not required in bromination of phenol?

(d) Boiling point of ethanol is higher in comparison to methoxymethane. Give reason.

(e) $(\text{CH}_3)_3\text{C} - \text{O} - \text{CH}_3$ on reaction with HI gives CH_3OH and $(\text{CH}_3)_3\text{C} - \text{I}$ as the main products and not $(\text{CH}_3)_3\text{C} - \text{OH}$ and CH_3I .

(f) Write the mechanism of the following reaction:

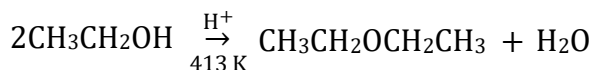

(g) Account for the following:

Preparation of ethers by acid dehydration of secondary or tertiary alcohols is not a suitable method.

32. (a) The activation energy of a reaction is 75.2 kJ mol^{-1} in the absence of a catalyst and $50.14 \text{ kJ mol}^{-1}$ with a catalyst. How many times will the rate of reaction increase in the presence of the catalyst if the reaction proceeds at 25°C ? ($R = 8.314 \text{ J K}^{-1} \text{ mol}^{-1}$)

(b) Explain the following terms:

(i) Rate of a reaction

(ii) Activation energy of a reaction

(c) The decomposition of phosphine (PH_3), proceeds according to the following equation:

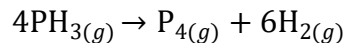

It is found that the reaction follows the following rate equation: $\text{Rate} = k[\text{PH}_3]$

The half-life period of PH_3 is 37.9 s at 120°C .

- (i) How much time is required for $\frac{3}{4}$ th of PH_3 to decompose?
- (ii) What fraction of the original sample of PH_3 remains behind after 1 minute?

OR

- (a) How much time is required for the completion of a zero-order reaction?
- (b) How does the value of rate constant vary with reaction concentration?
- (c) Draw a schematic graph showing how the rate of a first order reaction changes with change in concentration of the reactant.
- (d) Rate of a reaction is given by $\text{Rate} = k[A]^2[B]$

What are the units for the rate and the rate constant for this reaction?

33. (a) Draw the structures of optical isomers of each of the following complex ions:

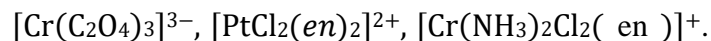

(b) Draw the structure and write the hybridisation state of Co in cis- $[\text{Co}(\text{NH}_3)_4\text{Cl}_2]^+$.

OR

(a) Using crystal field theory, draw energy level diagram, write electronic configuration of the central metal atom/ion and determine the magnetic moment value for the following:



(b) Explain with example homoleptic and heteroleptic complexes.

SAMPLE PAPER

CHEMISTRY

CLASS 12

SET-10
CHEMISTRY

Time Allowed: 3 Hours

Maximum Marks: 70

General Instructions:

Read the following instructions carefully.

- (a) There are 33 questions in this question paper with internal choice.
- (b) SECTION A consists of 16 multiple-choice questions carrying 1 mark each.
- (c) SECTION B consists of 5 short answer questions carrying 2 marks each.
- (d) SECTION C consists of 7 short answer questions carrying 3 marks each.
- (e) SECTION D consists of 2 case-based questions carrying 4 marks each.
- (f) SECTION E consists of 3 long answer questions carrying 5 marks each.
- (g) All questions are compulsory.
- (h) Use of log tables and calculators is not allowed.

SECTION A

The following questions are multiple-choice questions with one correct answer. Each question carries 1 mark. There is no internal choice in this section.

1. In which of the following complexes, primary and secondary valencies are not correctly marked against the compound?
 - (a) $[\text{Cr}(\text{NH}_3)_6]\text{Cl}_3$; $p = 3, s = 6$
 - (b) $\text{K}_2[\text{PtCl}_4]$; $p = 2, s = 4$
 - (c) $[\text{Pt}(\text{NH}_3)_2\text{Cl}_2]\text{Cl}_2$; $p = 4, s = 4$
 - (d) $[\text{Cu}(\text{NH}_3)_4]\text{SO}_4$; $p = 4, s = 4$
2. Given below are few mixtures formed by mixing two components. Which of the following binary mixtures will have same composition in liquid and vapour phase?
 - (i) Ethanol + Chloroform
 - (ii) Nitric acid + Water
 - (iii) Benzene + Toluene
 - (iv) Ethyl chloride + Ethyl bromide
 - (a) (i) and (iii)
 - (b) (i) and (ii)

- (c) (i), (ii) and (iii)
 (d) (iii) and (iv)

3. In a set of reactions, acetic acid yielded a product *S*. The structure of *S* would be

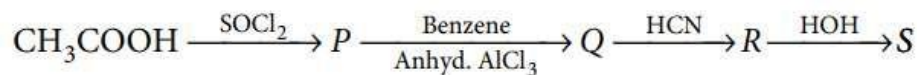

4. Which of the following is correct statement?

- (a) Starch is a polymer of α -glucose.
 (b) Amylose is a component of cellulose.
 (c) Proteins are compounds of only one type of amino acids.
 (d) Sucrose is a reducing sugar.

5. An organic compound of molecular formula $\text{C}_3\text{H}_6\text{O}$ did not give a silver mirror with Tollens' reagent but give an oxime with hydroxylamine. It may be

- (a) $\text{CH}_2 = \text{CH} - \text{CH}_2 - \text{OH}$
 (b) CH_3COCH_3
 (c) $\text{CH}_3\text{CH}_2\text{CHO}$
 (d) $\text{CH}_2 = \text{CH} - \text{OCH}_3$

6. A student set up the following apparatus to determine the hydrogen ion concentration of solution *X*.

The cell is, $M | \text{H}_2(g) | 2\text{H}^+_{(aq)} || \text{Cu}^{2+}_{(aq)} | \text{Cu}(s)$. The best material for electrode *M* would be

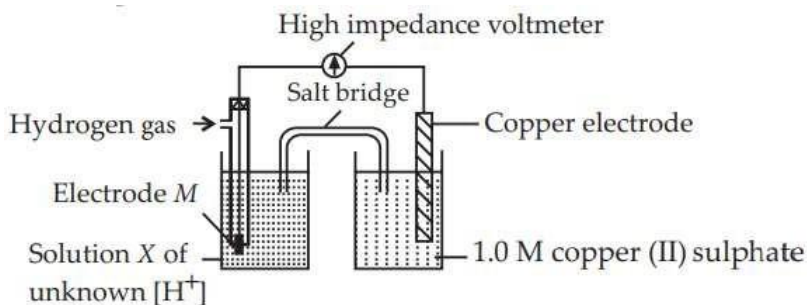

- (a) polished copper metal

- (c) copper metal coated with oxide
- (b) platinum metal coated with platinum oxide
- (d) platinum metal coated with finely divided platinum.
7. A 0.0020 m aqueous solution of an ionic compound $[\text{Co}(\text{NH}_3)_5(\text{NO}_2)]\text{Cl}$ freezes at -0.00732°C . Number of moles of ions which 1 mol of ionic compound produces on being dissolved in water will be ($K_f = -1.86^\circ\text{C}/\text{m}$)
- (a) 3
- (b) 4
- (c) 1
- (d) 2
8. In context with the transition elements, which of the following statements is incorrect?
- (a) In addition to the normal oxidation states, the zero oxidation state is also shown by these elements in complexes.
- (b) In the highest oxidation states, the transition metals show basic character and form cationic complexes.
- (c) In the highest oxidation states of the first five transition elements (Sc to Mn), all the 4s and 3d electrons are used for bonding.
- (d) Once the d^5 configuration is exceeded, the tendency to involve all the 3d electrons in bonding decreases
9. Which of the following is the major species in a solution of lysine at $\text{pH} = 3.5$?
- (a)

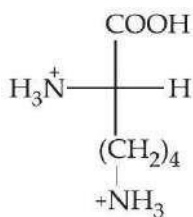

(b)

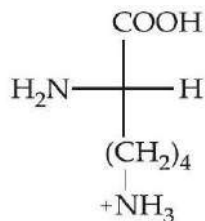

(c)

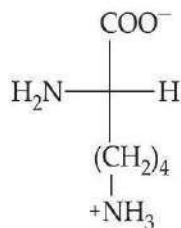

(d)

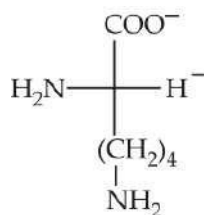

10. Which of the following complexes will have four isomers?

- (a) $[\text{Co}(\text{en})(\text{NH}_3)_2\text{Cl}_2]\text{Cl}$
- (b) $[\text{Co}(\text{PPh}_3)_2(\text{NH}_3)_2\text{Cl}_2]\text{Cl}$
- (c) $[\text{Co}(\text{en})_3]\text{Cl}_3$
- (d) $[\text{Co}(\text{en})_2\text{Cl}_2]\text{Cl}$

11. The end product (Z) in the given sequence of reaction is

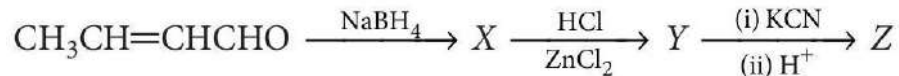

- (a) $\text{CH}_3\text{CH} = \text{CHCH}_2\text{COOH}$
- (b) $\text{CH}_3\text{CH}_2\text{CH}_2\text{COOH}$
- (c) $\text{CH}_3\text{CH} = \text{CHCOOH}$
- (d) $\text{CH}_3\text{CH}(\text{Cl})\text{CH}_2\text{COOH}$

12. Phenol on treatment with excess of conc. HNO_3 gives

- (a) *o*-nitrophenol
- (b) *p*-nitrophenol
- (c) *o*- and *p*-nitrophenol
- (d) 2,4,6-trinitrophenol.

13. Given below are two statements labelled as Assertion (A) and Reason (R).

Assertion (A) : In strongly acidic solutions, aniline becomes more reactive towards electrophilic reagents.

Reason (R) : The amino group being completely protonated in strongly acidic solution, the lone pair of electrons on the nitrogen is no longer available for resonance.

Select the most appropriate answer from the options given below:

- (a) Both A and R are true and R is the correct explanation of A.
- (b) Both A and R are true but R is not the correct explanation of A.
- (c) A is true but R is false.
- (d) A is false but R is true.

14. Given below are two statements labelled as Assertion (A) and Reason (R).

Assertion (A): All enzymes found in cells are invariably proteins which catalyse biological reactions.

Reason (R): Enzymes act efficiently at a moderate temperature and pH.

Select the most appropriate answer from the options given below:

- (a) Both A and R are true and R is the correct explanation of A.
- (b) Both A and R are true but R is not the correct explanation of A.
- (c) A is true but R is false.
- (d) A is false but R is true.

15. Given below are two statements labelled as Assertion (A) and Reason (R).

Assertion (A): Replacement of $-Cl$ group by $-OH$ in chlorobenzene is easier if nitro group is present in the ring. Reason (R): Nitro group leads to strengthen the $C - Cl$ bond in chlorobenzene.

Select the most appropriate answer from the options given below:

- (a) Both A and R are true and R is the correct explanation of A.
- (b) Both A and R are true but R is not the correct explanation of A.
- (c) A is true but R is false.
- (d) A is false but R is true.

16. Given below are two statements labelled as Assertion (A) and Reason (R)

Assertion (A) : In transition elements, ns orbital is filled up first and $(n - 1)d$ afterwards, during ionization ns electrons are lost prior to $(n - 1)d$ electrons.

Reason (R) : The effective nuclear charge felt by $(n - 1)d$ electrons is higher as compared to that by ns electrons. Select the most appropriate answer from the options given below:

- (a) Both A and R are true and R is the correct explanation of A.
- (b) Both A and R are true but R is not the correct explanation of A.

(c) A is true but R is false.

(d) A is false but R is true.

SECTION B

This section contains 5 questions with internal choice in one question. The following questions are very short answer type and carry 2 marks each.

17. Write equations of the following reactions:

(a) Oxidation of propan-1-ol with alkaline KMnO_4 solution.

(b) Treating phenol with chloroform in the presence of aqueous NaOH followed by hydrolysis.

OR

Illustrate with examples the limitations of Williamson's synthesis for the preparation of certain types of ethers.

18. What are bidentate ligands? Explain with examples.

19. Heptane and octane form an ideal solution. At 373 K, the vapour pressure of the two liquid components are 105.2kPa and 46.8kPa respectively. What will be the vapour pressure of a mixture of 26.0 g of heptane and 35.0 g of octane?

20. Two moles of organic compound 'A' on treatment with a strong base gives two compounds 'B' and 'C'. Compound 'B' on dehydrogenation with Cu gives 'A' while acidification of 'C' yields carboxylic acid 'D' with molecular formula of CH_2O_2 . Identify the compounds A, B, C and D and write all chemical reactions involved.

21. (a) Complete the following reaction:



(b) Draw the structure of the compound whose IUPAC name is 4-chloropentan-2-one.

SECTION C

This section contains 7 questions with internal choice in one question. The following questions are short answer type and carry 3 marks each.

22. Answer the following questions (any 2):

(a) Show the steps of reactions in the Stephen's method for production of acetaldehyde?

(b) Complete the reactions (i) and (ii). Give name, if any, to the reaction (i) and one medicinal use of the product formed in (ii).

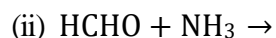
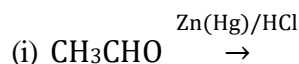

(c) Convert: (i) Acetaldehyde to methane (ii) Acetaldehyde to acetone.

23. (a) Calculate $\Delta_r G^\circ$ for the reaction:

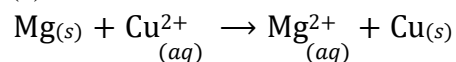

Given $E_{\text{cell}}^\circ = +2.71 \text{ V}$, $1 \text{ F} = 96500 \text{ C mol}^{-1}$

(b) Why is alternating current used for measuring resistance of an electrolytic solution?

24. Compound (A) with molecular formula, $\text{C}_4\text{H}_9\text{Br}$ was treated with *aq.* KOH solution. The rate of this reaction depends upon the concentration of the compound 'A' only. When another optically active isomer 'B' of this compound was treated with *aq.* KOH solution, the rate of reaction was found to be dependent on the concentration of compound and KOH both.

(i) Write down the structural formulae of both compounds 'A' and 'B'.

(ii) Out of these two compounds, which one will be converted to the product with inverted configuration?

25. (a) Define order of reaction.

(b) A certain reaction takes 5 minutes for initial concentration 0.5 mol L^{-1} to become 0.25 mol L^{-1} and another 5 minutes to become 0.125 mol L^{-1} . What is the order and specific rate constant of the reaction?

26. (a) Explain the completion of the following reactions with NaBr and conc. H_2SO_4 .



(ii)

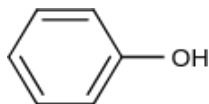

(b) Phenols and alcohols behave as Bronsted acids. Explain.

27. 1.22 g of benzoic acid is dissolved in 100 g of acetone (K_b for acetone = $1.7 \text{ K kg mol}^{-1}$) and 100 g of benzene ($K_b = 2.6 \text{ K kg mol}^{-1}$). The elevations in boiling points ΔT_b is 0.17°C and 0.13°C respectively.

(a) What are molar masses of benzoic acids in two solvents?

(b) Calculate the value of ' i ' for benzoic acid in acetone and explain whether it undergoes association or dissociation.

28. Using Valence bond theory, explain the following in relation to the paramagnetic complex, $[\text{Mn}(\text{CN})_6]^{3-}$.

(a) Type of hybridization

(b) Magnetic moment value

(c) Type of complex - Inner or outer orbital complex

SECTION D

The following questions are case -based questions. Each question has an internal choice and carries 4(1 + 1 + 2) marks each. Read the passage carefully and answer the questions that follow.

29. At constant temperature and volume, X decomposes as

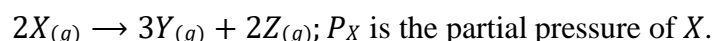

Observation No.	Time (in minute)	P (in mm of Hg)
1	0	800
2	100	400
3	200	200

Answer the following questions:

(a) What is the molecularity of the reaction?

OR

What is the order of reaction with respect to X ?

(b) Find the time for 75% completion of the reaction.

(c) Find the total pressure when pressure of X is 700 mm of Hg.

30. Strengthening the Foundation: Chargaff Formulates His "Rules"

Many people believe that James Watson and Francis Crick discovered DNA in the 1950s. In reality, this is not the case. Rather, DNA was first identified in the late 1860s by Swiss chemist Friedrich Miescher. Then, in the decades following Miescher's discovery, other scientists-notably, Phoebus Levene and Erwin Chargaff carried out a series of research efforts that revealed additional details

about the DNA molecule, including its primary chemical components and the ways in which they joined with one another. Without the scientific foundation provided by these pioneers, Watson and Crick may never have reached their groundbreaking conclusion of 1953: that the DNA molecule exists in the form of a three-dimensional double helix.

Chargaff, an Austrian biochemist, as his first step in this DNA research, set out to see whether there were any differences in DNA among different species. After developing a new paper chromatography method for separating and identifying small amounts of organic material, Chargaff reached two major conclusions:

- (i) The nucleotide composition of DNA varies among species.
- (ii) Almost all DNA, no matter what organism or tissue type it comes from maintain certain properties, even as its composition varies. In particular, the amount of adenine (A) is similar to the amount of thymine (T), and the amount of guanine (G) approximates the amount of cytosine (C). In other words, the total amount of purines ($A + G$) and the total amount of pyrimidines ($C + T$) are usually nearly equal. This conclusion is now known as "Chargaff's rule."

Chargaff's rule is not obeyed in some viruses. These either have single- stranded DNA or RNA as their genetic material.

Answer the following questions:

- (a) A segment of DNA has 100 adenine and 150 cytosine bases. What is the total number of nucleotides present in this segment of DNA?
- (b) A sample of hair and blood was found at two sites. Scientists claim that the samples belong to same species. How did the scientists arrive at this conclusion?
- (c) The sample of a virus was tested and it was found to contain 20% adenine, 20% thymine, 20% guanine and the rest cytosine. Is the genetic material of this virus (i) DNA- double helix (ii) DNA- single helix (iii) RNA? What do you infer from this data?

OR

How can Chargaff's rule be used to infer that the genetic material of an organism is double- helix or single- helix?

SECTION E

The following questions are long answer type and carry 5 marks each. All questions have an internal choice.

31. Attempt any five of the following:

- (a) Give the structures of *A*, *B* and *C* in the following reactions:

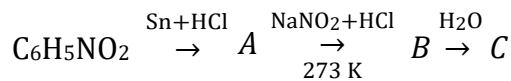

- (b) How is the following conversion carried out? Aniline to *p*-Hydroxyazobenzene.
- (c) How will you bring about the following conversion? Nitrobenzene to phenol.
- (d) Why are the secondary amines more basic than primary amines? Explain.
- (e) Write the complete chemical reaction for the conversion of aniline to sulphanilic acid.
- (f) Why is benzenediazonium chloride not stored and is used immediately after its preparation?
- (g) Under what reaction conditions (acidic/basic), the coupling reaction of aryldiazonium chloride with aniline is carried out?

32. (a) State reasons for the following:

- (i) Rusting of iron is said to be an electrochemical phenomenon.
- (ii) For a weak electrolyte, its molar conductance in dilute solutions increases sharply as its concentration in solution is decreased.

(b) Equivalent conductance of a 0.0128 N solution of acetic acid is $1.4\text{ mho cm}^2\text{ eq}^{-1}$ and conductance at infinite dilution is $391\text{ mho cm}^2\text{ eq}^{-1}$. Calculate degree of dissociation and dissociation constant of acetic acid.

(c) Calculate the standard cell potential, ΔG° and equilibrium constant of the following reaction of galvanic cell:

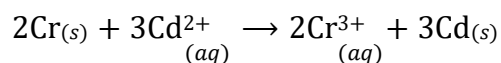

(Given: $E^\circ_{\text{Cr}^{3+}/\text{Cr}} = -0.74\text{ V}$, $E^\circ_{\text{Cd}^{2+}/\text{Cd}} = -0.40\text{ V}$)

OR

(a) An aqueous solution of AuCl_3 was electrolysed with a current of 0.5 A until 1.20 g of gold had been deposited on the cathode. At another electrode in series with this, the only reaction was the evolution of O_2 . Find

- (i) number of moles of oxygen
- (ii) the number of coulombs passed through the solution
- (iii) the duration of electrolysis.

(b) (i) Why electrolysis of $\text{NaBr}_{(aq)}$ and $\text{NaI}_{(aq)}$ gives Br_2 and I_2 respectively while that of $\text{NaF}_{(aq)}$ gives O_2 instead of F_2 ?

- (ii) Why Λ_m° for acetic acid cannot be determined experimentally?
33. (a) (i) Out of the ions Ag^+ , Co^{2+} and Ti^{4+} which will be coloured in aqueous solution?
(ii) If each one of the above ionic species is placed in a magnetic field, how will they respond and why?
- (b) Explain the following:
- (i) Acidified $\text{K}_2\text{Cr}_2\text{O}_7$ solution turns green when sodium sulphite is added.
(ii) A ferrous salt decolourises acidified KMnO_4 solution.

OR

- (a) Which metal in the first transition series ($3d$ -series) exhibits +1 oxidation state most frequently and why?
- (b) How would you account for the following?
Highest fluoride of Mn is MnF_4 whereas the highest oxide is Mn_2O_7 .
- (c) Account for the following:
- (i) The lowest oxide of transition metal is basic whereas the highest oxide is amphoteric or acidic.
(ii) Manganese exhibits the highest oxidation state of +7 among the 3rd series of transition elements.
- (d) How is the variability in oxidation states of transition elements different from that of non-transition elements? Illustrate with examples.

